

# PD Series



## Engine-Powered Forklifts

EPA Tier-4 Diesel  
4,000 / 5,000 / 6,000 / 7,000  
Capacities

**UNICARRIERS**  
FORKLIFT

MAIN TRUCK SPECIFICATIONS								
CHARACTERISTICS	1	Model	Model designation		PFD40M	PFD50M	PFD60M	
	2	Rated Load Capacity		lb (kg)	4000 (1800)	5000 (2250)	6000 (2700)	
	3	Load Center	Distance	in (mm)	24 (600)	24 (600)	24 (600)	
	4	Power Type			Diesel	Diesel	Diesel	
	5	Operator Orientation			Sit Down	Sit Down	Sit Down	
DIMENSIONS	6	Tire Type	Front & rear		Pneumatic	Pneumatic	Pneumatic	
	7	Wheels	Number (x=driven) front/rear		2 x / 2	2 x / 2	2 x / 2	
	8	Mast	Maximum fork height	in (mm)	131.5 (3340)	131.5 (3340)	130.5 / (3315)	
	9		Standard freelif	in (mm)	5.5 (140)	5.5 (140)	5.7 (145)	
	10	Forks	Thickness & width	in (mm)	1.6 x 4 (40x100)	1.6 x 4 (40x100)	1.8 x 4.9 (45 x 125)	
	11		Length	in (mm)	42 (1070)	42 (1070)	42 (1070)	
	12	Tilt Angle	Standard mast - fwd/back	degree	6/10	6/10	6/10	
	13	Overall Dimensions	Length (to face of forks)	in (mm)	98.0 (2490)	100 / (2550)	107.0 (2720)	
	14		Width (single/dual tires)	in (mm)	45.3 (1150) / 64.6 (1640)	45.3 (1150) / 64.6 (1640)	50.2 (1275) / 67.5 (1715)	
	15		Mast lowered (OHL)	in (mm)	84.5 (2145)	84.5 (2145)	90.5 (2299)	
	16		Mast extended with LBR	in (mm)	180 (4572)	180 (4572)	178.5 (4534)	
	17		Height - top of OHG	in (mm)	82.9 (2105)	82.9 (2105)	83.7 (2125)	
	18		Height - top of standard LBR	in (mm)	48.0 (1220)	48.0 (1220)	48.0 (1220)	
	19		Width - standard carriage	in (mm)	39.5 (1003)	39.5 (1003)	39.5 (1003)	
	20	Grade Clearance	Ramp breakover angle	tan (%)	24	24	24	
	21		Departure angle	tan (%)	24	21	23	
	22		Approach angle	tan (%)	25	25	28	
	23	Turning Radius	Minimum outside	in (mm)	86.6 (2200)	87.8 (2230)	93.7 (2380)	
	24		Front	in (mm)	17.9 (455)	17.9 (455)	19.3 (491)	
	25		Rear	in (mm)	17.1 (735)	19.5 (496)	20.9 (531)	
	26	Min Right Angle Stack	Add load length & clearance	in (mm)	105 (2667)	106 (2685)	113.0 (2870)	
	PERFORMANCE	27	Speeds Maximum	Travel - forward or reverse	mph (kmh)	11.2 (18.0)	10.9 (17.5)	10.9 (17.5)
		28		Lift - full/empty	fpm (mm/sec)	120 / 126 (609 / 640)	120 / 126 (609 / 640)	96.5 (490) / 100 (508)
		29		Lowering - full/empty	fpm (mm/sec)	98.4 (500)	98.4 (500)	98.4 (500)
		30	Drawbar Pull Max	Full load	lb (kg)	3960 (1800)	4520 (2050)	4540 (2060)
		31		Empty	lb (kg)	2220 (1006)	3960 (1800)	3960 (1795)
32	Gradeability Max (1.2 mph)	Full/empty	tan (%)	42 / 36	37 / 31	30 / 26		
WEIGHT	33	Truck Weight	Standard truck - no load	lb (kg)	7610 (3450)	8210 (3724)	9640 (4373)	
	34	Weight Distribution	Front axle - empty	lb (kg)	3340 (1515)	3260 (1479)	3920 (1779)	
	35		Rear axle - empty	lb (kg)	4270 (1937)	4950 (2246)	5720 (2595)	
	36		Front axle - with rated load	lb (kg)	10060 (4564)	11650 (5285)	13890 (6301)	
	37		Rear axle - with rated load	lb (kg)	1550 (704)	1560 (708)	1750 (794)	
CHASSIS & WHEELS	38	Tire Size	Front - single tire		7.00-12-12PR	7.00-12-12PR	28x9-15-12PR	
	39		Rear		6.00-9-12PR	6.00-9-12PR	6.50-10-12PR	
	40	Wheelbase		in (mm)	63 (1600)	63 (1600)	66.9 (1700)	
	41		Tread - Center of Tire	Front / rear	in (mm)	37.8 / 38.6 (960/980)	37.8/38.6 (960/980)	41.7/38.6 (1060/980)
	42		Front - dual tires	in (mm)	47.4 (1205)	47.5 (1205)	47.2 (1200)	
	43	Headroom	SIP to bottom of OHG	in (mm)	41 (1020)	41 (1020)	41 (1020)	
	44	Counterweight Height		in (mm)	45 (1120)	45 (1120)	45 (1120)	
	45	Step Height		in (mm)	19 (461)	19 (461)	19 (480)	
	46	Ground Clearance	Under mast	in (mm)	4.6 (117)	4.6 (117)	5.4 (137)	
	47		Under power unit	in (mm)	6.6 (168)	6.6 (168)	7.4 (188)	
	48		Under frame (WB center)	in (mm)	6.6 (167)	6.6 (167)	7.4 (188)	
49	Service Brake	Type		Foot Operated, Hydraulic	Foot Operated, Hydraulic	Foot Operated, Hydraulic		
50	Parking Brake	Type		Hand, Mechanical	Hand, Mechanical	Hand, Mechanical		
51	Steering	Type		Full Hydraulic	Full Hydraulic	Full Hydraulic		
DRIVE LINE	52	Engine	Model		4EG	4EG	4EG	
	53	Rated Output	SAE gross	hp (kW) @ rpm	48.0 (36.0) @ 2250	48.0 (36.0) @ 2250	48.0 (36.0) @ 2250	
	54	Rated Torque	SAE gross	ft-lb (Nm) @ rpm	131 (177) @ 1800	131 (177) @ 1800	131 (177) @ 1800	
	55	Displacement		cu in (cm <sup>3</sup> )	203 (3300)	203 (3300)	203 (3300)	
	56	Transmission	Type		Powershift	Powershift	Powershift	
	57		Number speeds - fwd/rev		1/1	1/1	1/1	

MAIN TRUCK SPECIFICATIONS			
CHARACTERISTICS	1	PFD70M	
	2	7000 (3175)	
	3	24 (610)	
	4	Diesel	
	5	Sit Down	
DIMENSIONS	6	Pneumatic	
	7	2 x / 2	
	8	131.5 (3340)	
	9	5.9 (150)	
	10	2 x 5 (51 x 127)	
	11	42 (1070)	
	12	6/10	
	13	110 (2794)	
	14	50.8 (1291) / 67.5 (1715)	
	15	90.5 (2300)	
	16	180 (4572)	
	17	84.3 (2142)	
	18	48.0 (1220)	
	19	39.5 (1003)	
	20	26	
	21	23	
	22	29	
	23	96.1 (2441)	
	24	19.5 (496)	
	25	23.4 (595)	
	26	116 (2947)	
	PERFORMANCE	27	11.2 (18)
		28	96.5 (490) / 100 (508)
		29	98.4 (500)
		30	4140 (1877)
		31	3620 (1642)
32		24 / 21	
WEIGHT	33	10590 (4804)	
	34	3820 (1733)	
	35	6770 (3071)	
	36	15500 (7031)	
	37	2130 (967)	
	38	28x9-15-12PR	
	39	6.50-10-12PR	
CHASSIS & WHEELS	40	66.9 (1700)	
	41	41.7/38.6 (1060/980)	
	42	47.2 (1200)	
	43	41 (1020)	
	44	46 (1150)	
	45	20 (490)	
	46	5.7 (145)	
	47	8.0 (204)	
	48	8.0 (204)	
	49	Foot Operated, Hydraulic	
	50	Hand, Mechanical	
51	Full Hydraulic		
DRIVE LINE	52	4EG	
	53	48.0 (36.0) @ 2250	
	54	131 (177) @ 1800	
	55	203 (3300)	
	56	Powershift	
	57	1/1	

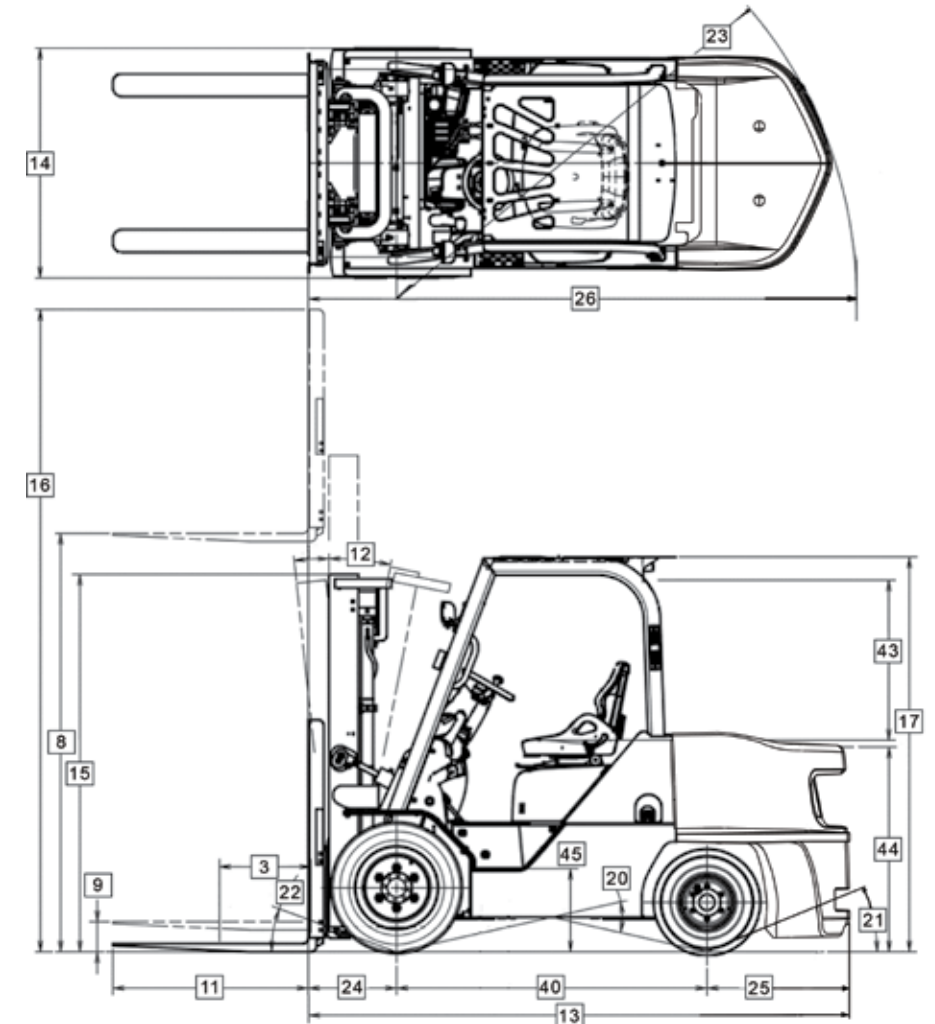

# Reliability.

It's the defining trait of our brand and our forklifts.



UniCarriers' roots extend back over 100 years, and over that time, strong, reliable performance has always been the hallmark of our people and our equipment.

Today, our unrivaled reliability continues to provide UniCarriers' customers with a competitive edge. And together, we move the merchandise that moves world commerce with greater efficiency, economy and reliability.

Which brand do you trust?  
The one you never have to think about.

**We Never Quit.**



[LogisnextAmericas.com/UniCarriers](https://LogisnextAmericas.com/UniCarriers)



UECV0404 05/2026

© 2026 Logisnext Americas Inc. UniCarriers® is a registered trademark of Logisnext Co., Ltd. Logisnext Americas, Inc. reserves the right to make product changes relating to colors, equipment, specifications or available options without notice. For more information, contact your UniCarriers Forklift representative.