

MLW Series



Electric Walkie Pallet Trucks

24 Volt AC-Powered
1,600 / 2,000 kg. Capacities



UNICARRIERS
[FORKLIFT]

		Specifications			MLW 160	
Characteristics	1.1	Manufacturer			UniCarriers	
	1.2	Manufacturer's model designation			MLW 160	
	1.3	Power source: battery, diesel, LP gas, gasoline			Battery	
	1.4	Operation type: pedestrian, standing, seating			Pedestrian	
	1.5	Load capacity	Q*	kg	1600	
	1.6	Load center distance	c*	mm	600	
	1.8	Load wheel axle to fork face (forks lowered)	x*	mm	960	
	1.9	Wheelbase	y*	mm	1360	
	Weights	2.1	Truck weight with maximum battery weight			kg 431
2.2		Axle loadings with nominal load & maximum battery weight, drive / load side			kg 635 / 1396	
2.3		Axle loadings without load & with maximum battery weight, drive / load side			kg 332 / 99	
Wheels & Tires	3.1	Tires: PT = Power Thane, Vul = Vulkollan, drive / load side			Vul / Vul	
	3.2	Tire dimensions, drive side			mm 85 x 90	
	3.3	Tire dimensions, load side			mm 230 x 70	
	3.4	Caster wheel dimensions, diameter x width			mm 100 x 40	
	3.5	Number of wheels, drive / load side (x = driven)			2+1x / 2	
	3.6	Truck width (center of tires), drive side	b10*	mm	480	
	3.7	Truck width (center of tires), load side	b11*	mm	355 / 375 / 495	
Dimensions	4.2	Height with mast lowered (see tables)			h1* mm –	
	4.4	Lift height			h3* mm 135	
	4.8	Seat or stand height			mm –	
	4.9	Height of tiller arm / steering console, min / max			h14* mm 1050 / 1372	
	4.15	Fork height, fully lowered			h13* mm 85	
	4.19	Overall length, platform up / down			l1* mm 1648	
	4.20	Length to fork face, platform up / down			l2* mm 498	
	4.21	Overall width			b1/b2* mm 720	
	4.22	Fork dimensions, thickness/ width / length			s/e/l* mm 55 / 165 / 1150	
	4.25	Outside width over forks			b5* mm 520 / 540 / 660	
	4.32	Ground clearance, center of wheelbase (forks lowered)			m2* mm 30	
	4.33	Working aisle width (Ast) with 1000 x 1200mm pallet, load crosswise, platform up / down			Ast* mm 1694	
	4.34	Working aisle width (Ast) with 800 x 1200mm pallet, load lengthwise, platform up / down			Ast* mm 1894	
	4.35	Turning radius			Wa* mm 1454	
	Performance	5.1	Travel speed, with / without load			km/h 6.0 / 6.0
5.2		Lifting speed, with / without load			m/s 0.035 / 0.045	
5.3		Lowering speed, with/ without load			m/s 0.05 / 0.05	
5.7		Gradeability, with / without load			% 10.0 / 20.0	
5.10		Service brakes (mechanical / hydraulic / pneumatic)			Electric	
Drive	6.1	Drive motor capacity (60 min short duty)			kW 1.0	
	6.2	Lift motor output at 15% duty factor			kW 0.8	
	6.4	Battery voltage / capacity at 5-hour discharge			V/Ah 24 / 150	
	6.5	Battery weight			kg 151	
Other	8.1	Type of drive control			Stepless	
	8.4	Level of noise at the ear level of the driver according to EN 12 053:2001 and EN ISO 4871, drive / lift / idle LpAZ			dB(A) 62 / 69 / 0	
		Body tremble according to EN 13 059:2002			m/s ² –	
	Hand tremble according to EN 13 059:2002			m/s ² <2.5		

*varies according to battery size

All rights reserved to change above specifications

		MLW 180		MLW 200	
Characteristics	1.1	UniCarriers		UniCarriers	
	1.2	MLW 180		MLW 200	
	1.3	Battery		Battery	
	1.4	Pedestrian		Pedestrian	
	1.5	1800		2000	
	1.6	600		600	
	1.8	960		960	
	1.9	1424		1424	
	Weights	2.1	502		634
2.2		805 / 1496		864 / 1770	
2.3		381 / 121		475 / 159	
Wheels & Tires	3.1	Vul / Vul		Vul / Vul	
	3.2	85 x 75		85 x 75	
	3.3	230 x 70		230 x 70	
	3.4	100 x 40		100 x 40	
	3.5	2+1x / 4		2+ 1x / 4	
	3.6	480		480	
	3.7	355 / 375 / 495		355 / 375 / 495	
Dimensions	4.2	–		–	
	4.4	135		135	
	4.8	–		–	
	4.9	1050 / 1372		1050 / 1372	
	4.15	85		85	
	4.19	1712		1712	
	4.20	562		562	
	4.21	720		720	
	4.22	55 / 165 / 1150		55 / 165 / 1150	
	4.25	520 / 540 / 660		520 / 540 / 660	
	4.32	30		30	
	4.33	1758		1758	
	4.34	1958		1958	
	4.35	1518		1518	
	Performance	5.1	6.0 / 6.0		6.0 / 6.0
5.2		0.035 / 0.045		0.04 / 0.06	
5.3		0.099 / 0.076		0.099 / 0.078	
5.7		10.0 / 20.0		10.0 / 20.0	
5.10		Electric		Electric	
Drive	6.1	1.0		1.0	
	6.2	0.8		1.2	
	6.4	24 / 250		24 / 250-375*	
	6.5	212		212-294	
Other	8.1	Stepless		Stepless	
	8.4	62 / 69 / 0		65 / 67 / 0	
		–		–	
	<2.5		<2.5		

*varies according to battery size

All rights reserved to change above specifications

MLW 160-200

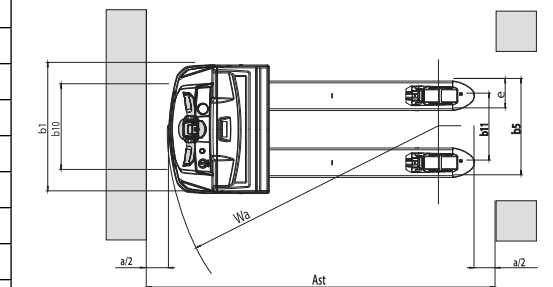
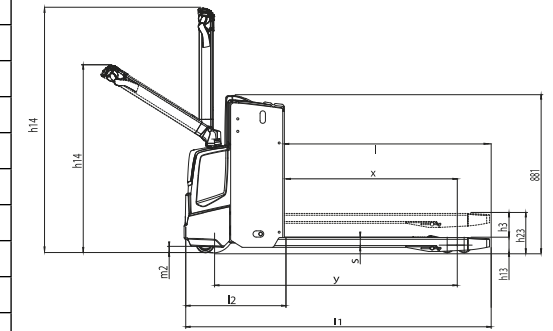

Sealed chassis offers protection against dirt, dust and other particles to reduce wear.

Oil-filled, sealed transmission is shock-resistant, quiet and requires little maintenance.

High-efficiency electronic system features waterproof components for maximum reliability – even in damp conditions.

Robust forks with welded construction, and rounded tips for effortless pallet entry, providing extra strength and durability.

Market-leading lift height of 135 mm allows easy handling on steep ramps and loading docks, even with damaged pallets.

High stability is ensured by use of two linked castor wheels – next to the central drive wheel – in addition to the two load wheels. Versatile battery compartment accommodates DIN and BS size batteries with a variety of capacities for maximum compatibility with user's equipment and needs.

Choice of two performance modes via key switch enhances safety, energy efficiency and productivity.

Reliability.

It's the defining trait of our brand and our forklifts.

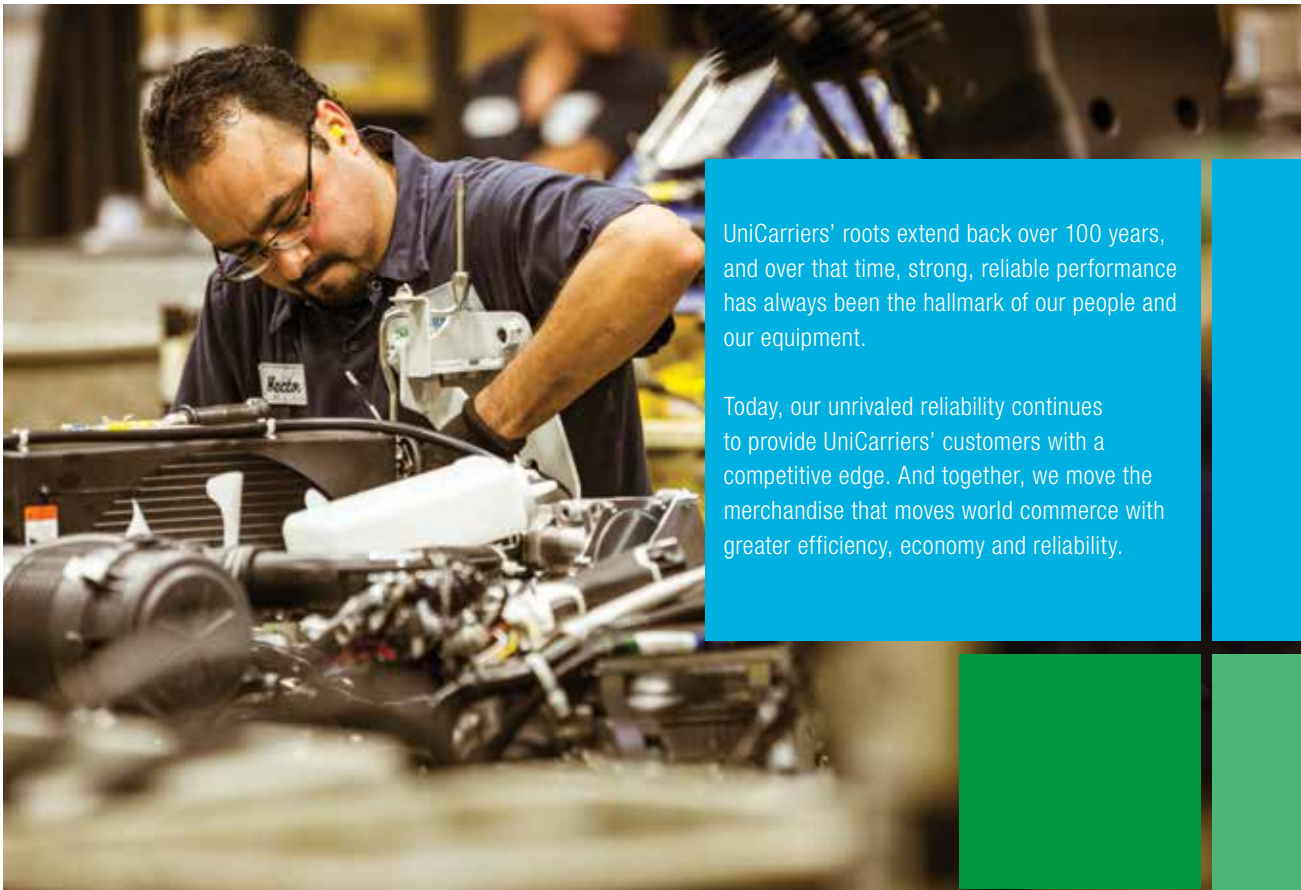

UniCarriers' roots extend back over 100 years, and over that time, strong, reliable performance has always been the hallmark of our people and our equipment.

Today, our unrivaled reliability continues to provide UniCarriers' customers with a competitive edge. And together, we move the merchandise that moves world commerce with greater efficiency, economy and reliability.

Which brand do you trust?
The one you never have to think about.

We Never Quit.



LogisnextAmericas.com/UniCarriers



UECN0406LA 04/2026

© 2026 Logisnext Americas Inc. UniCarriers® is a registered trademark of Logisnext Co., Ltd. Logisnext Americas, Inc. reserves the right to make product changes relating to colors, equipment, specifications or available options without notice. For more information, contact your UniCarriers Forklift representative.