

WSX & WGX Series



Straddle Stackers /
Counterbalance
Stackers

24 Volt AC-Powered
3,000 & 4,000 lbs. Capacities

UNI CARRIERS
[FORKLIFT]

NEVER QUIT.

YOUR JOB DOESN'T STOP, AND NEITHER SHOULD YOUR FORKLIFTS.
THAT'S WHERE WE COME IN.

Your application isn't just picking product from aisles upon aisles. There's loading docks, freezers and ramps and moving that product where it needs to go all while operators are constantly getting on and off the trucks for all the daily tasks that keeps business moving.

Flexibility is the name of the game. And that's where the WSX & WCX excels.



Power:	24V AC Electric
Maneuverability:	Designed for tight aisles, heavy loads and maximum agility
Environment:	Well suited for trailer loading/unloading and load transfer/stacking
Travel Distance:	Short to medium distances
Lift:	Max fork height of 152" in.

WSX & WCX Series In Your Application

Performance, reliability, control, safety and comfort – the WSX & WCX incorporates them all to excel in a wide-range of fast-paced industrial applications, such as:

- Narrow Aisle Applications (WSX)
- Tight Operating Environments (WSX)
- Trailer Loading / Unloading (WCX)
- Load Transfer / Stacking (WCX)

Reliability: YOUR FORKLIFT NEEDS TO BE READY WHEN YOU NEED IT. UPTIME IS NOT OPTIONAL.

Easy Service

Our bolt-on mast design allows quick and easy access for servicing.

No Tools

The drivetrain and other major components can be easily accessed without tools.

Simply Smarter

The innovative design of these stacker trucks allows digital communication between all operational controls on the steer handle to the truck's controller. This means **multiple signals travel through the same wire**. Plus, every minute the truck is on, it's self-monitoring to assure reliability.

Low Maintenance and High Efficiency

Extremely reliable, our 24V brushless drive motor requires little maintenance. Extremely efficient, it **uses less energy per cycle** to stay up and running longer between battery charges. Its maintenance-free electronic horn eliminates rust due to condensation for longer economic life.

Protection Where It Counts

Thermal protection systems that slow or shut down the truck in response to high temperatures protect the drive motor, controller and your investment.

Smart Electric Brake

Regenerative motor torque, proportional plugging and our spring-applied electronically released disc brake work together to reduce component wear, **extend part life and eliminate the need for adjustments.**



Fewer Moving Parts

Hall Effect speed and acceleration control simplifies maintenance and limits downtime due to its non-contact design that eliminates mechanical wiping action, potentiometers, and heaters.

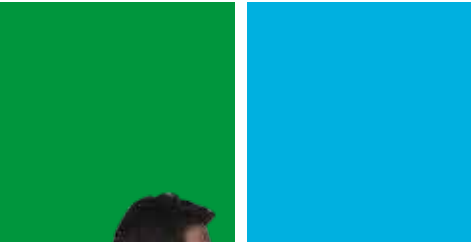

Built for Serviceability

The design provides easy service access to:

- Drive unit assembly
- Pump motor brushes
- Rotation sensing encoder
- Brake system
- Lubrication fittings

Self-Diagnostics

On-board diagnostics are readily available through our optional multi-function LCD meter panel — to alert you to potential difficulties, pinpoint the source and troubleshoot problems.



Driving Efficiency

The AC drive motor is brushless, eliminates forward and reverse contactors, uses fewer components and requires less maintenance to keep you up and running. Both the drive motor and controller feature **thermal protection systems** to slow or shut down the truck in response to high temperatures. And if service is required, **the motor is mounted vertically for easier access**— to get you back to work faster.



Our heavy-duty DC hydraulic lift pump effectively delivers hydraulic oil to a system that features a check valve, flow regulator and return filtering line. This protects the system against environmental contaminants.

Performance:

YOUR APPLICATION DESERVES BOTH POWER AND EFFICIENCY.



Our AC Motor Does More for Less

Greater torque and faster speeds are only the beginning of what our proven 5.2 HP brushless AC drive motor delivers. This 24V system features an advanced proven motor controller/AC inverter that **distributes consistent power as needed** to the AC drive motor or the heavy-duty DC pump motor. The result? Consistently high performance across the battery range, with **longer run times between charging**.

A Turn for the Better

You'll get the exceptional stability that comes from the WSX model's wide wheelbase and tight turning radius. **Its 190° steering arc**, ball-bearing steering mechanism, large steering control head, and spring-loaded handle all contribute to easily navigating in the tightest of spaces.

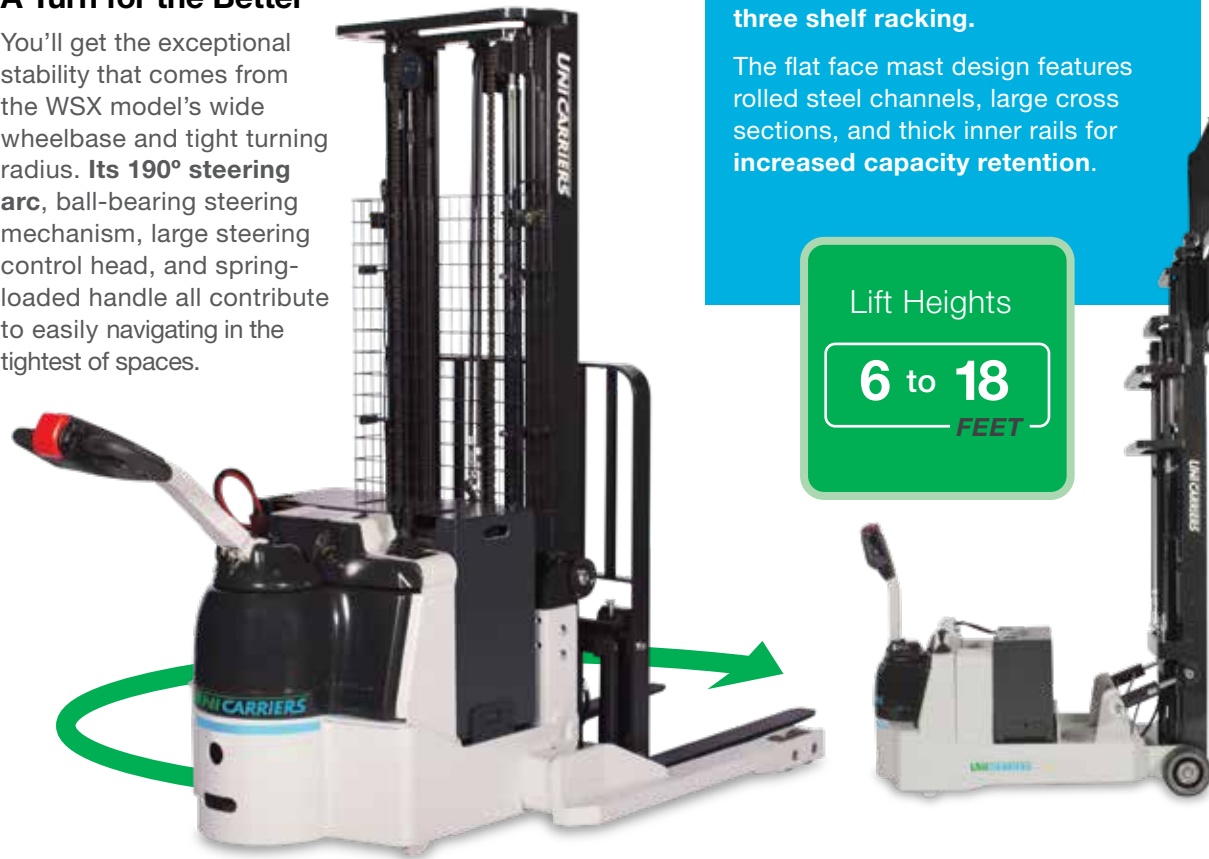

Reach Higher

At 217 inches (18 feet), our lift height is among the highest in the industry — **sized just right for two and three shelf racking**.

The flat face mast design features rolled steel channels, large cross sections, and thick inner rails for **increased capacity retention**.

Lift Heights
6 to 18
FEET

Solid Performance

The rugged frame keeps your stacker up and running — and durable, high gloss, scratch-resistant powder coat paint will keep it looking good.

Control:

YOUR PRODUCTS DESERVE PURE PRECISION. WE PUT IT AT YOUR FINGERTIPS.

Speed Limits

A sealed, non-contact proximity switch detects when the forks are raised above free lift on three-stage masts (or at approximately 47" for 2W masts). This system triggers the controller to automatically reduce travel speed to 1.0 mph (1.5 km/h).



Easy Does It

The ergonomic layout of the control head includes our **thumb-operated rotary controls**, which can be accessed from either side to easily adjust direction and speed. Our "Soft Touch" switches also allow easy lifting or lowering of loads.

Complete Control

Hydraulic control levers for lift/lower and tilt functions are conveniently located on the top, right side of the WCX, offering smooth control to feather the load. Levers are available as an option on the WSX.

A Multi-Faceted Display for a Multi-Faceted Truck

The standard Multi-Function Digital Indicator includes a battery discharge indicator with lift interrupt, hour meter gauge, and fault-code display.

For even greater control, add the optional Multi-Function LCD Display (shown) that features:



PIN Access: Personal codes for up to 5 different operators

Performance Modes: Custom settings to match driver capabilities and optimize productivity

On-Board Diagnostics: Fast, easy troubleshooting and adjustment

An efficient, high-power drive unit combined with an 18-ft lift height provides you with the performance you need to complete tough tasks with more speed, accuracy and productivity.

And while competitive systems feature large, bulky connectors, which house a web of complex wiring, our exclusive CAN System uses just four wires (data in/out and power in/out) in the controller head. The result? **A greatly simplified system with enhanced dependability.**

Comfort: YOUR OPERATOR SHOULD BE AS PRODUCTIVE AT THE END OF THE SHIFT AS AT THE BEGINNING.



Perfectly Positioned

Manual levers for lift/lower and tilt control are located on the top right of the WCX's power unit where they're easily accessible to operators. Manual lift/lower levels are available as an option on WSX models.

Optional auxiliary lever also shown



More Comfort By Design

The spring-loaded handle and control head are ergonomically designed to maximize both operator control and comfort — delivering the ultimate in speed and maneuverability with minimum effort.

Controlled Stop

The Smart Electric Brake engages whenever the handle is in the upper or lower brake range, ensuring the equipment **can only be operated when the handle is in the proper operating position.**



Requiring significantly **less effort** versus twist grip controls, our fingertip design reduces operator fatigue and allows **precise travel speed control.**



WSX

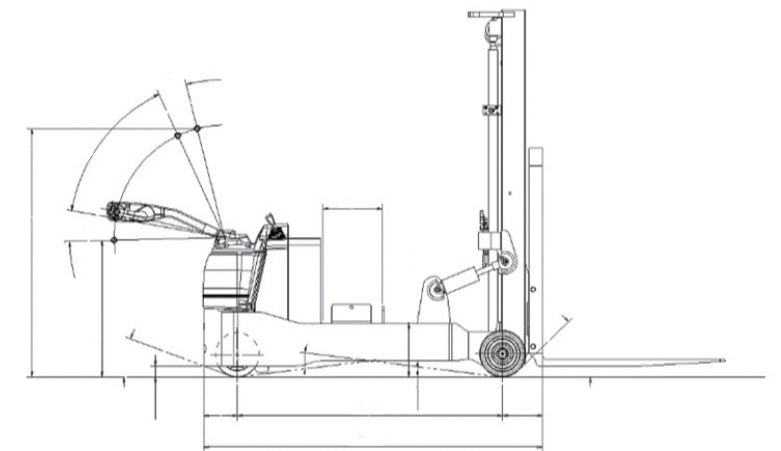
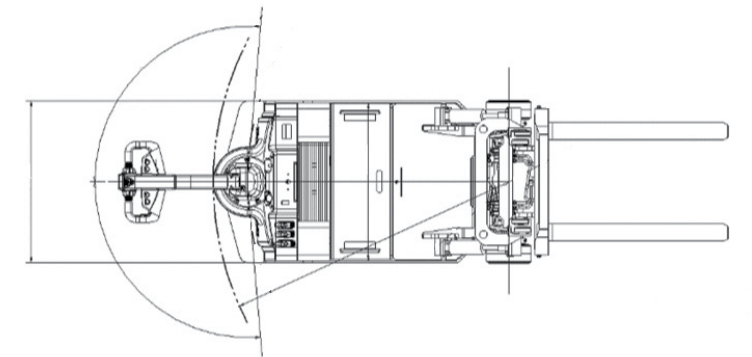
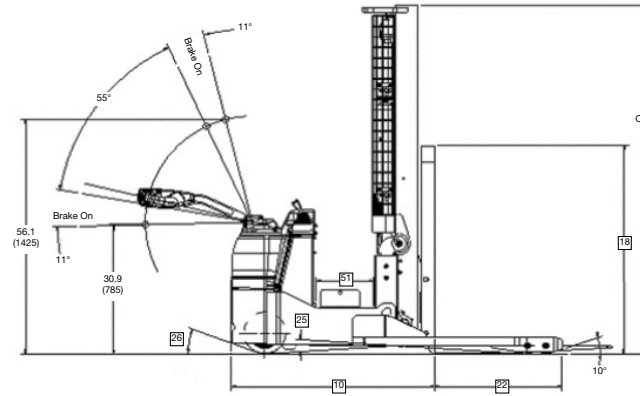
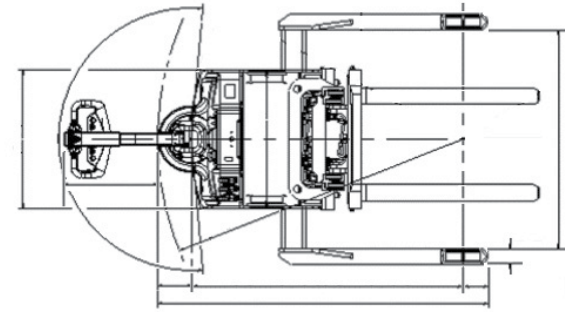

WCX

Specifications

MAIN TRUCK SPECIFICATIONS

CHARACTERISTICS	1			UniCarriers	UniCarriers	UniCarriers	UniCarriers	
	2			WSX30S	WSX30	WSX40S	WSX40	
	3			WSXT2W6S30V	WSXT2W6G30V	WSXT2W6S40V	WSXT2W6G40V	
	Manufacturer's Name							
	Model	Model designation						
		Long model code						
	Rated Load Capacity	At 24" (610) load center	lb (kg)	3000 (1360)	3000 (1360)	4000 (1810)	4000 (1810)	
	Power Type	Electric	voltage	24v	24v	24v	24v	
	Operator Type			Walkie Straddle	Walkie Straddle	Walkie Straddle	Walkie Straddle	
DIMENSIONS	Tire Type	Drive / load		Rubber / Poly	Rubber / Poly	Rubber / Poly	Rubber / Poly	
	Wheels	Number - drive / load	x=driven	1 x / 4	1 x / 4	1 x / 4	1 x / 4	
	Overall Dimensions	Length - to tip of base legs	in (mm)	74.0 (1880)	78.5 (1995)	74.0 (1880)	78.5 (1995)	
		Length - to face of forks	in (mm)	44.2 (1120)	48.7 (1235)	44.2 (1120)	48.7 (1235)	
	Mast (3F385)	Width - Power Head	in (mm)	33 (840)	33 (840)	33 (840)	33 (840)	
		Maximum fork height (MFH)	in (mm)	152 (3850)	152 (3850)	152 (3850)	152 (3850)	
		Fork lowered height (TOF)	in (mm)	1.5 (40)	1.5 (40)	1.5 (40)	1.5 (40)	
		Mast lowered (OHL)	in (mm)	71.3 (1815)	71.3 (1815)	71.3 (1815)	71.3 (1815)	
		Mast extended with LBR	in (mm)	200.9 (5105)	200.9 (5105)	200.9 (5105)	200.9 (5105)	
		Standard freelif with LBR	in (mm)	23.3 (590)	23.3 (590)	23.3 (590)	23.3 (590)	
		Width - Class II carriage	in (mm)	32.4 (825)	32.4 (825)	32.4 (825)	32.4 (825)	
		Height - top of standard LBR	in (mm)	48 (1220)	48 (1220)	48 (1220)	48 (1220)	
	Tilt Angle	Standard mast - fwd/back	degree	-	-	-	-	
	Outrigger	Height	in (mm)	4 (100)	4 (100)	4 (100)	4 (100)	
		Width - Nominal I.D. min-max (2" increments)	in (mm)	36 - 50 (915 - 1270)	36 - 50 (915 - 1270)	36 - 50 (915 - 1270)	36 - 50 (915 - 1270)	
		Length (face of fork to tip of base legs)	in (mm)	29.8 (760)	29.8 (760)	29.8 (760)	29.8 (760)	
	Forks	Length x width x thickness	in (mm)	42 x 4 x 1.5 (1070 x 100 x 40)	42 x 4 x 1.5 (1070 x 100 x 40)	42 x 4 x 1.5 (1070 x 100 x 40)	42 x 4 x 1.5 (1070 x 100 x 40)	
		Spread (o.d.) - Min. / Max.	in (mm)	8 (205) / 31.6 (800)	8 (205) / 31.6 (800)	8 (205) / 31.6 (800)	8 (205) / 31.6 (800)	
	Grade Clearance	Ramp breakover angle	%	13.9	12.8	13.9	12.8	
		Departure angle	%	36	36	36	36	
	Overhang	Front / Rear	in (mm)	6.4 (165) / 7.7 (195)	6.4 (165) / 7.7 (195)	6.4 (165) / 7.7 (195)	6.4 (165) / 7.7 (195)	
	Turning Radius	Minimum outside	in (mm)	67.8 (1723)	72.4 (1838)	67.8 (1723)	72.4 (1838)	
	Min Right Angle Stack	42" ID Base Legs, Add load length & clearance	in (mm)	See Right Angle Stacking Chart	See Right Angle Stacking Chart	See Right Angle Stacking Chart	See Right Angle Stacking Chart	
	PERFORMANCE	Speeds Maximum	Travel - loaded / unloaded	mph (km/h)	3.6 (5.8) / 3.7 (5.9)	3.6 (5.8) / 3.7 (5.9)	3.6 (5.8) / 3.7 (5.9)	3.6 (5.8) / 3.7 (5.9)
			Lift - loaded / unloaded	fpm (mm/sec)	30 (152) / 50 (254)	30 (152) / 50 (254)	30 (152) / 50 (254)	30 (152) / 50 (254)
			Lowering - loaded / unloaded	fpm (mm/sec)	50 (254) / 50 (254)	50 (254) / 50 (254)	50 (254) / 50 (254)	50 (254) / 50 (254)
		Drawbar Pull Maximum	Full load / empty - 3 min rating	lb (kN)	830(3.7) / 888 (3.9)	830(3.7) / 888 (3.9)	830(3.7) / 888 (3.9)	830(3.7) / 888 (3.9)
	Gradeability Maximum	Full load - 5 min rating	%	11.4	11.4	11.4	11.4	
	WEIGHT	Truck Weight	No Load (max. battery)	lb (kg)	2735 (1240)	2800 (1270)	2735 (1240)	2800 (1270)
Weight Distribution		Full load - Drive / Load wheel each (max. battery)	lb (kg)	2075/2215 (945/1005)	2200/2195 (1000/995)	2000/2750 (910/1250)	2180/2690 (990/1225)	
		No load - Drive / Load wheel each (min. battery)	lb (kg)	2140/645 (970/285)	2170/700 (985/320)	2140/665 (970/300)	2170/700 (985/320)	
CHASSIS & WHEELS	Tire Size	Drive tire	in (mm)	10 x 5 (255 x 127)	10 x 5 (255 x 127)	10 x 5 (255 x 127)	10 x 5 (255 x 127)	
		Load wheels	in (mm)	4 x 2.75 (265 x 100)	4 x 2.75 (265 x 100)	4 x 2.75 (265 x 100)	4 x 2.75 (265 x 100)	
	Wheelbase		in (mm)	59.9 (1521)	64.4 (1636)	59.9 (1521)	64.4 (1636)	
	Tread - Center of Tire	Load wheels (w/ 42" base leg)	in (mm)	48.2 (1224)	48.2 (1224)	48.2 (1224)	48.2 (1224)	
	Power Unit Height		in (mm)	34.7 (882)	34.7 (882)	34.7 (882)	34.7 (882)	
	Ground Clearance	Lowest point - skid pad	in (mm)	0.6 (15)	0.6 (15)	0.6 (15)	0.6 (15)	
		Under frame, center of wheelbase	in (mm)	1.85 (47)	1.85 (47)	1.85 (47)	1.85 (47)	
	Brake	Service	type	Regen	Regen	Regen	Regen	
		Parking	type	Auto-Applied / Electronic Release	Auto-Applied / Electronic Release	Auto-Applied / Electronic Release	Auto-Applied / Electronic Release	
	DRIVE LINE	Steering	On-demand		Manual Tiller Arm	Manual Tiller Arm	Manual Tiller Arm	Manual Tiller Arm
Traction Motor		AC	kW (HP)	3.9 (5.2)	3.9 (5.2)	3.9 (5.2)	3.9 (5.2)	
Pump Motor		DC Series - Rating @ 20% duty cycle	kW (HP)	4.7 (6.4)	4.7 (6.4)	4.7 (6.4)	4.7 (6.4)	
Hydraulic Control ¹				Electric	Electric	Electric	Electric	
BATTERY	Compartment Size ²	W x L x H ("X" x "Y" x "Z") - Max.	in (mm)	31.9 x 8.9 x 32 (810 x 225 x 810)	31.9 x 13.5 x 32 (810 x 340 x 815)	31.9 x 8.9 x 32 (810 x 225 x 810)	31.9 x 13.5 x 32 (810 x 340 x 815)	
	Battery	Lead acid	Type	E	E	E	E	
		Capacity - Max.	Ah (6-hr)	840	840	840	840	
	Weight	Minimum / Maximum	lb (kg)	320 / 900 (145 / 405)	950 / 1500 (430 / 680)	320 / 900 (145 / 405)	950 / 1500 (430 / 680)	
	Lead Length	Position B / SB-175 Red	in (mm)	20 (505)	20 (505)	20 (505)	20 (505)	

MAIN TRUCK SPECIFICATIONS

CHARACTERISTICS	1			UniCarriers	UniCarriers	
	2			WCX30	WCX40	
	3			WCXT2W5G30V	WCXT2W5G40V	
	Manufacturer's Name					
	Model	Model designation				
		Long model code				
	Rated Load Capacity	At 24" (610) load center	lb (kg)	3000 (1360)	4000 (1810)	
	Power Type	Electric	voltage	24v	24v	
	Operator Type			Walkie Counterbalance	Walkie Counterbalance	
DIMENSIONS	Tire Type	Drive / load		Poly / Poly	Poly / Poly	
	Wheels	Number - drive / load	x=driven	1x / 2	1x / 2	
	Overall Dimensions	Length (to face of forks)	in (mm)	77.9 (1979)	77.9 (1979)	
		Width	in (mm)	37.3 (950)	37.3 (950)	
	Mast	Maximum fork height (MFH)	in (mm)	152 (3850)	152 (3850)	
		Fork lowered height (TOF)	in (mm)	1.6 (40)	1.6 (40)	
		Mast lowered (OHL)	in (mm)	71.1 (1805)	71.1 (1805)	
		Mast extended with LBR	in (mm)	200.7 (5100)	200.7 (5100)	
		Standard freelif with LBR	in (mm)	23.3 (590)	23.3 (590)	
		Width - Class II carriage	in (mm)	32.4 (825)	32.4 (825)	
		Height - top of standard LBR	in (mm)	48 (1220)	48 (1220)	
	Tilt Angle	Standard mast - fwd/back	degree	3 / 3	3 / 3	
	Forks	Length x width x thickness	in (mm)	42 x 4 x 1.5 (1070 x 100 x 40)	42 x 4 x 1.5 (1070 x 100 x 40)	
		Spread (o.d.) - Min. / Max.	in (mm)	10 (255) / 31.6 (800)	10 (255) / 31.6 (800)	
	Grade Clearance	Ramp breakover angle	%	24	24	
		Departure angle	%	36	36	
	Overhang	Front / rear	in (mm)	9.6 (245) / 7.7 (195)	9.6 (245) / 7.7 (195)	
	Turning Radius	Minimum outside (chassis)	in (mm)	69.4 (1765)	69.4 (1765)	
	Min Right Angle Stack	48" L x 40" W pallet (add clearance)	in (mm)	127 (3225)	127 (3225)	
	PERFORMANCE	Speeds Maximum	Travel - loaded / unloaded	mph (km/h)	2.8 (4.5) / 2.9 (4.7)	2.8 (4.5) / 2.9 (4.7)
			Lift - loaded / unloaded	fpm (mm/sec)	30 (152) / 50 (254)	30 (152) / 50 (254)
			Lowering - loaded / unloaded	fpm (mm/sec)	50 (254) / 50 (254)	50 (254) / 50 (254)
		Drawbar Pull Maximum	Full load / empty - 3 min rating	lb (kN)	891 (3.96) / 1023 (4.55)	596 (2.65) / 1023 (4.55)
	Gradeability Maximum	Full load - 5 min rating	%	11.2	11.2	
	WEIGHT	Truck Weight	No load (min. battery)	lb (kg)	6185 (2805)	6185 (2805)
Weight Distribution		Full load - Drive / Load wheel each (min. battery)	lb (kg)	Consult Factory	Consult Factory	
		No load - Drive / Load wheel each (min. battery)	lb (kg)	Consult Factory	Consult Factory	
CHASSIS & WHEELS	Tire Size	Drive tire	in (mm)	10 x 5 (255 x 127)	10 x 5 (255 x 127)	
		Load wheel	in (mm)	10.5 x 4.5 (266 x 114)	10.5 x 4.5 (266 x 114)	
	Wheelbase		in (mm)	61 (1550)	61 (1550)	
	Tread - Center of Tire	Load wheel	in (mm)	32.8 (835)	32.8 (835)	
	Power Unit Height		in (mm)	34.6 (880)	34.6 (880)	
	Ground Clearance	Lowest point	in (mm)	2.5 (60)	2.5 (60)	
		Under frame, center of wheelbase	in (mm)	3.7 (90)	3.7 (90)	
	Brake	Service	type	Regen	Regen	
		Parking	type	Auto-Applied / Electronic Release	Auto-Applied / Electronic Release	
DRIVE LINE	Steering	Manual		Tiller Arm	Tiller Arm	
	Traction Motor	AC	kW (HP)	3.9 (5.2)	3.9 (5.2)	
	Pump Motor	DC Series - Rating @ 20% duty cycle	kW (HP)	4.77 (6.4)	4.77 (6.4)	
	Hydraulic Control ¹	Parking		Lift/Lower - Electric & Manual / Tilt Lever - Manual	Lift/Lower - Electric & Manual / Tilt Lever - Manual	
BATTERY	Compartment Size ²	W x L x H ("X" x "Y" x "Z") - Max.	in (mm)	35.75 x 13.5 x 32 (905 x 340 x 815)	35.75 x 13.5 x 32 (905 x 340 x 815)	
	Battery	Lead Acid	Type	E	E	
		Capacity-Max.	Ah (6-hr)	840	840	
	Weight	Minimum / Maximum	lb (kg)	950 / 1500 (430 / 680)	950 / 1500 (430 / 680)	
	Lead Length		in (mm)	20 (505)	20 (505)	

¹ Optional Manual Lift/Lower or Aux. Lever controls are available.

² WSX30, WSX40 - Battery compartment size with adjustable retainers: 30.9 x 13.5 x 32 with optional rollers & side gates: 31.1 x 13.5 x 31
WSX30S, WSX40S - Battery compartment size with adjustable retainers: 30.9 x 9.5 x 32

¹ Optional Manual Auxiliary Lever control is available.

² Battery compartment size with adjustable retainers: 30.9 x 13.5 x 32 with optional rollers & side gates: 31.1 x 13.5 x 31

Reliability.

It's the defining trait of our brand and our forklifts.



UniCarriers' roots extend back over 100 years, and over that time, strong, reliable performance has always been the hallmark of our people and our equipment.

Today, our unrivaled reliability continues to provide UniCarriers' customers with a competitive edge. And together, we move the merchandise that moves world commerce with greater efficiency, economy and reliability.

Which brand do you trust?
The one you never have to think about.

We Never Quit.



LogisnextAmericas.com/UniCarriers



UECN0402 04/2026

© 2026 Logisnext Americas Inc. UniCarriers is a registered trademark of Logisnext Co., Ltd. Logisnext Americas, Inc. reserves the right to make product changes relating to colors, equipment, specifications or available options without notice. For more information, contact your UniCarriers Forklift representative.