

RPX & WRPX Series



Walkie Rider &
Walkie Pallet
Trucks

24 Volt AC-Powered
6,000 & 8,000 lbs. Capacities

UNI CARRIERS
[FORKLIFT]

NEVER QUIT.

YOUR JOB DOESN'T STOP, AND NEITHER SHOULD YOUR FORKLIFTS. THAT'S WHERE WE COME IN.

Your application isn't just picking product from aisles upon aisles. There's loading docks, freezers and ramps and moving that product where it needs to go all while operators are constantly getting on and off the trucks for all the daily tasks that keeps business moving.

Flexibility is the name of the game. And that's where the RPX & WPX excels.



Power:

24 AC Electric

Maneuverability:

Engineered to excel in harsh conditions

Environment:

Navigates tight aisles, uneven loads and traveling to and from the dock

Travel Distance:

Medium and long runs

Lift:

9.25" in. from ground

RPX & WPX Series In Your Application

Performance, reliability, control, safety and comfort – the RPX & WPX incorporates them all to excel in a wide-range of fast-paced industrial applications, such as:

- Manufacturing
- Warehousing
- Cooler/Freezers
- Multiple Operating Environments

Performance:

YOUR APPLICATION DESERVES BOTH POWER AND EFFICIENCY.

Your operation can't shut down or slow down because of the equipment you use. That's why our pallet trucks are designed to deliver maximum uptime. From the tips of the forks to the switches on the handle, our trucks are engineered to do more, withstand more, and deliver more, every day.

Unlike competitive equipment, our standard pallet trucks can operate in all environments, moving swiftly and reliably from coolers and freezers down to -20°F (-28.9°C) to dry ambient environments. The temperatures in your operation may vary, but the quality and reliability of our pallet trucks never do.



Our Controller Area Network (CAN) System Is Simply Smarter

This innovative design allows digital communication between all operational controls on the steer handle to the truck's controller, allowing multiple signals to travel through the same wire. Plus, every minute the truck is on, it's self-monitoring to assure reliability.

Compare our design to that of our competitors. While competitive systems feature large, bulky connectors which house a web of complex wiring, our exclusive CAN System uses just four wires (data in/out and power in/out) in the controller head. The result? A greatly simplified system with enhanced dependability.

Our AC Motor Does More for Less

Greater torque and faster speeds are only the beginning of what our proven 5.2 HP brushless AC drive motor delivers. This 24 Volt system features enhanced thermal capabilities and delivers consistent power during normal battery discharge, while using less energy per cycle. The result? Consistent performance shift after shift, with longer run times between charging.

Since easier maintenance is a key to greater reliability, our high-performance AC Motor is mounted vertically for better heat dissipation and ease of service.



Wet, Dry, Hot or Cold Our Sealed Systems Can Do it All

With the RPX, one truck can do it all — moving from coolers and freezers to dry ambient environments where condensation can occur. As a safeguard, all of our pallet trucks are equipped with sealed switches, an epoxy coated control board, IP65 rated sealed controller, and sealed steer race — all housed within our rugged frame that's protected by a durable powder coat paint finish. Add in our other features like AC motor control, thermal cut back and onboard self-diagnostics, and you have one very versatile machine.



Protection of Key Components

Unique steer race and enclosed frame design help keep major components protected — including drive motor, controller and hydraulic system — resulting in less maintenance and longer life.



Simplified Maintenance Throughout

By making maintenance points more accessible, we cut the time and effort required to keep our machines and your operation moving. Consider this: every grease fitting is accessible from the top side of the truck, so no lifting is necessary.

Reliability:

YOUR FORKLIFT NEEDS TO BE READY WHEN YOU NEED IT. UPTIME IS NOT OPTIONAL.

Packed trailers, extensive shuttle runs, heavy loads, long days. You have to be tough to work in that kind of environment, and UniCarriers Pallet Trucks are built to not only withstand these conditions, but thrive in them. It's not just the rugged steel construction, but the innovative designs throughout our trucks that shield both machine and man from abuse.

Rise Above Costly Damage

Take control using the Auto-Lift feature to ensure forks are automatically at their maximum lift height during operation. Optional feature provides ample clearance over dock plates or uneven floors, reducing the chance of pallet damage or replacement of costly load carry components.



Protects Your Truck, Protects Your Budget

With our push design lift linkage, the solid steel tie rods never extend beyond the plane of the fork, but move down the middle, improving ground clearance, preventing possible damage, and reducing maintenance costs.

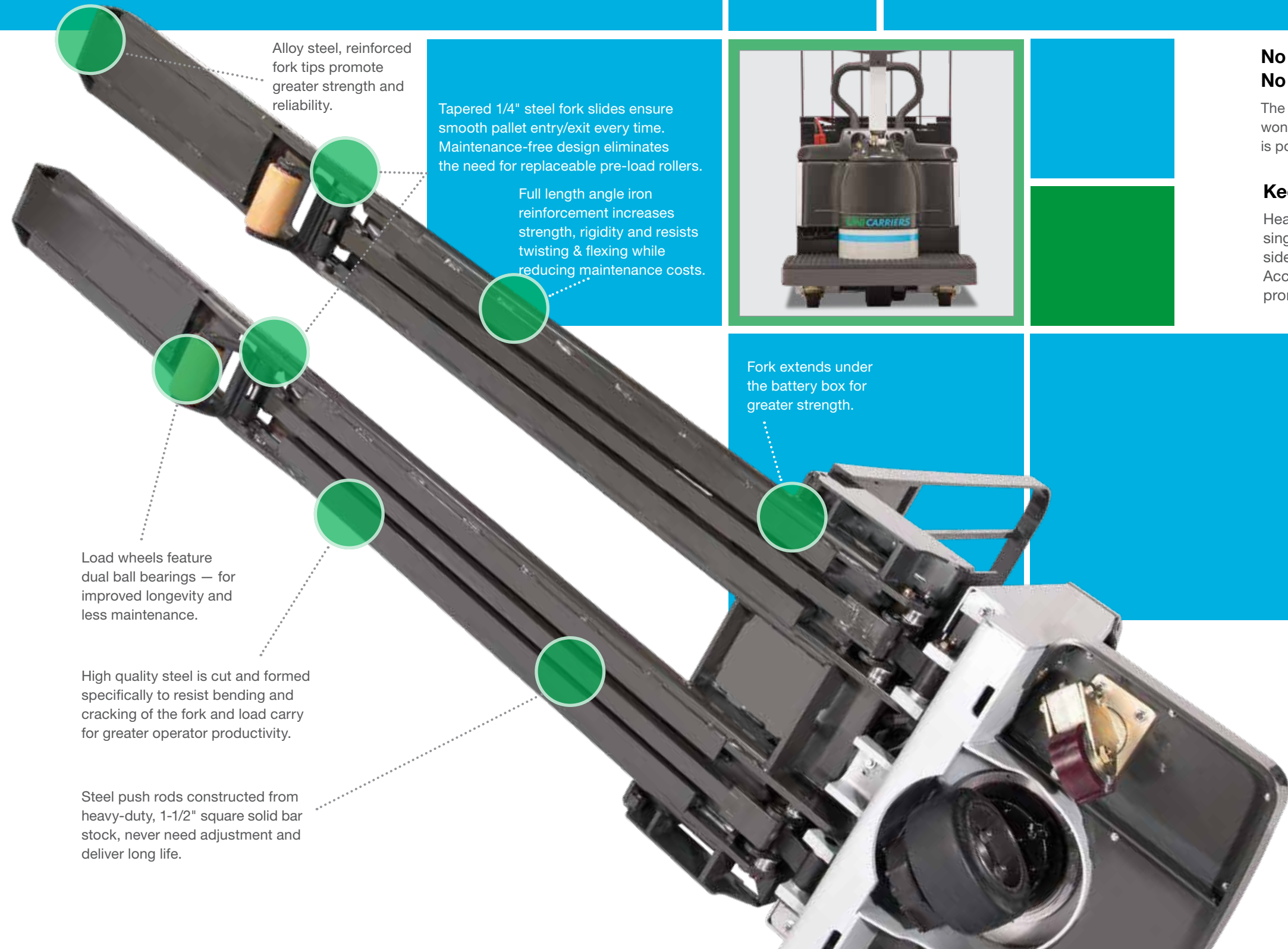

Alloy steel, reinforced fork tips promote greater strength and reliability.

Tapered 1/4" steel fork slides ensure smooth pallet entry/exit every time. Maintenance-free design eliminates the need for replaceable pre-load rollers.

Full length angle iron reinforcement increases strength, rigidity and resists twisting & flexing while reducing maintenance costs.

Fork extends under the battery box for greater strength.

Load wheels feature dual ball bearings — for improved longevity and less maintenance.

High quality steel is cut and formed specifically to resist bending and cracking of the fork and load carry for greater operator productivity.

Steel push rods constructed from heavy-duty, 1-1/2" square solid bar stock, never need adjustment and deliver long life.



No Bends, No Dents No Rust, No Problem

The hood and cover on our pallet trucks are made of rugged polycarbonate that won't bend, dent, fade or rust, while the entire frame (including the load carry) is powder coated inside and out, for even greater durability.

Keeps Your Business Rolling

Heavy duty, yet simple caster design incorporates single-point height adjustment and an angled side bracket to prevent dock plate hang-ups. Accessible grease fittings on swivel and axle help promote routine maintenance.



Control: YOUR PRODUCTS DESERVE PURE PRECISION. WE PUT IT AT YOUR FINGERTIPS.

Whether it's navigating tight aisles, handling heavy, uneven loads, picking multiple orders, or traveling to and from the dock, UniCarriers pallet trucks put you and your operators in control. From the ergonomic design of the steerhead to the size and comfort of the platform, our trucks have been engineered to put your operators in comfortable command of any situation.

Maintenance-free electronic horn design eliminates rust due to condensation for longer economic life.

Large safety reversing button changes truck direction if contact is made.

Requiring significantly less effort versus twist grip controls, our thumb-operated rotary controls allow the operator to easily adjust travel and direction from either side of the truck.

Hall Effect speed and acceleration control simplifies maintenance and limits downtime due to its non-contact design that eliminates mechanical wiping action, potentiometers, and heaters.

Sealed switches require no heaters or thermostats, are designed for a minimum of 5,000,000 actuations, and can operate in coolers, freezers and wet rooms at temperatures as low as -20°F (-28.9°C).

Steel reinforced fiberglass-filled polymer construction offers high impact resistance

Optional Sidetracker controls are strategically placed within easy reach for assured control of the truck when walking beside it — available with our Coast Control feature.

WPX Walkie Pallet Truck



When You Don't Need a Ride, the WPX Walkie Pallet Truck Gives You a Lift.

The WPX offers a durable, dependable, and versatile design for a wide range of applications in all kinds of operating environments. From manufacturing to warehousing to grocery, it's the one walkie pallet truck you can count on.

The WPX shares all the performance features of the RPX, including:

- 5.2 HP heavy-duty, three-phase brushless AC drive motor with enhanced thermal capabilities and greater torque
- Sealed switches and logic boards for operation in coolers, wet rooms, and freezers down to -20°F (-28.9°C)
- Controller Area Network (CAN) system uses just four wires to send multiple signals between the control handle and controller

- Rugged construction, including tubular steel steer handle
- Ergonomic features, including large, soft-touch switches
- String guards on all wheels
- Wide array of optional equipment, including Auto-Lift and multi-function LCD meter panel
- Lithium-Ion Batteries and Charger Options Available:

Smart power solutions are designed to communicate directly with the truck for increased efficiency and results. Maintenance-free, which reduces the total cost of ownership and downtime from traditional lead acid batteries.

Li-Ion batteries are covered by a 6-year, 3,600-cycles, with a 75% residual capacity guarantee.



MAIN TRUCK SPECIFICATIONS

CHARACTERISTICS	1	Manufacturer's Name		UniCarriers	UniCarriers	
	2	Model	Model designation	WPX60B	WPX80B	
	3	Long model code		WPXT2W1G60BV	WPXT2W1G80BV	
CHARACTERISTICS	4	Rated Load Capacity	Equally distributed load	lb (kg)	6000 (2720)	8000 (3630)
	5	Power Type	Electric	volt	24	24
	6	Operator Type			Walkie	Walkie
CHARACTERISTICS	7	Tire Type	Drive tire		Solid Rubber	Solid Rubber
	8	Load Wheels			Dyalon® A Poly	Dyalon® A Poly
	9	Wheels	Drive/load	(x=driven)	1x / 2	1x / 2
FORKS	10	Size	Outside spread	in (mm)	27 (685)	27 (685)
	11	Height	Raised position	in (mm)	9.25 (235)	9.25 (235)
	12		Lowered position	in (mm)	3.25 (82.5)	3.25 (82.5)
FORKS	13	Individual Width		in (mm)	9.25 (235)	9.25 (235)
	14	Overall Dimensions	Head length	in (mm)	34.5 (875)	34.5 (875)
	15	Width	Chassis	in (mm)	32 (815)	32 (815)
DIMENSIONS	16	Tires / Wheels	Drive tire - diameter x width	in (mm)	10 x 5 (254 x 127)	10 x 5 (254 x 127)
	17		Load wheels - diameter x width	in (mm)	3.25 x 6 (83 x 152)	3.25 x 6 (83 x 152)
	18	Speed - Travel	No load	mph (kph)	3.7 (5.9)	3.7 (5.9)
SPEED	19		Full load	mph (kph)	3.7 (5.9)	3.7 (5.9)
	20	Speed - Lift / Lower	No load	sec	3.6 / 5.1	3.6 / 5.1
	21		Full load	sec	5.1 / 4.8	6.1 / 4.7
BATTERY	22	Compartment Size*	Length x Width x Height	in (mm)	31.9 x 13.1 x 31.6 (810 x 330 x 800)	
	23	Amp Hr Capacity	Max (6-hr)	Ah	840	
	24	Weight	Min / Max	lb (kg)	800 / 1500 (365 / 680)	
	25	Lead Length	Position "B"	in (mm)	20 (508)	
	26	Connector		type	SB-175 Red	
	27	Battery Roller (Option)	Height from floor (forks lowered)	in (mm)	7.9 (200)	

*Battery compartment size with adjustable retainers - 30.9 x 13.1 x 32 (785 x 330 x 815); With optional rollers and side gates: 31.1 x 13.25 x 32 (790 x 330 x 815)

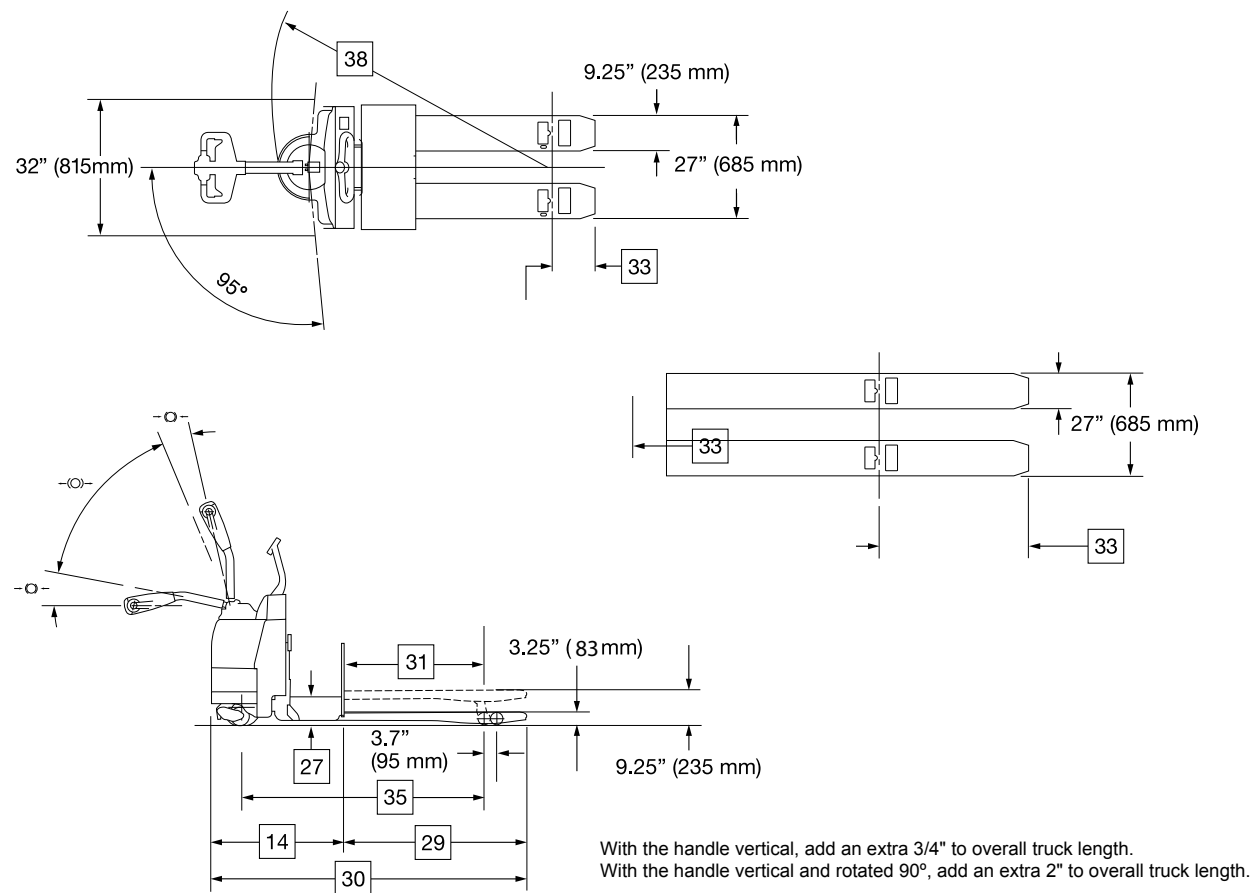

MAIN TRUCK SPECIFICATIONS

CHARACTERISTICS	1	Manufacturer's Name		UniCarriers	UniCarriers	
	2	Model	Model designation	RPX60B	RPX80B	
	3	Long model code		RPXT2W2G60BV	RPXT2W2G80BV	
CHARACTERISTICS	4	Rated Load Capacity	Equally distributed load	lb (kg)	6000 (2720)	8000 (3630)
	5	Power Type	Electric	volt	24v	24v
	6	Operator Type			Walkie / Rider	Walkie / Rider
CHARACTERISTICS	7	Tire Type	Drive tire		Solid Rubber	Solid Rubber
	8	Load Wheels			Poly	Poly
	9	Wheels	Drive/caster/load	(x=driven)	1x / 2 / 2	1x / 2 / 2
FORKS	10	Size	Outside spread	in (mm)	27 (685)	27 (685)
	11	Height	Raised position	in (mm)	9.25 (235)	9.25 (235)
	12		Lowered position	in (mm)	3.25 (82.5)	3.25 (82.5)
FORKS	13	Individual Fork Width		in (mm)	9.25 (235)	9.25 (235)
	14	Overall Dimensions	Head length	in (mm)	42.7 (1085)	42.7 (1085)
	15	Width	Chassis	in (mm)	35.6 (905)	35.6 (905)
DIMENSIONS	16	Tires / Wheels	Drive tire - dia. x width	in (mm)	10 x 5 (254 x 127)	10 x 5 (254 x 127)
	17		Caster wheels - dia. x width	in (mm)	5 x 2.5 (127 x 64)	5 x 2.5 (127 x 64)
	18		Load wheels - dia. x width	in (mm)	3.25 x 6 (83 x 152)	3.25 x 6 (83 x 152)
SPEED	19	Speed - Travel	No load	mph (kph)	9.1 (14.6)	9.1 (14.6)
	20		Full load	mph (kph)	6.6 (10.6)	6.1 (9.8)
	21	Speed - Lift / Lower	No load	sec.	3.6 / 5.1	3.6 / 5.1
SPEED	22		Full load	sec.	5.1 / 4.8	6.1 / 4.7
	23	Compartment Size*	Length x Width x Height	in (mm)	31.8 x 13 x 31.6 (810 x 330 x 803)	
	24	Amp Hr Capacity	Max (6-hr)	Ah	840	
BATTERY	25	Weight	Min / Max	lb (kg)	900 / 1500 (410 / 680)	
	26	Lead Length	Position "B"	in (mm)	20 (508)	
	27	Connector		type	SB-175 Red	
	28	Battery Roller (Option)	Height from floor (forks lowered)	in (mm)	7.9 (200)	
	29					
	30					

*Battery compartment size with adjustable retainers - 30.9 x 13 x 31.6 (785 x 330 x 803); With optional rollers and side gates: 31.1 x 13 x 32 (790 x 330 x 815)

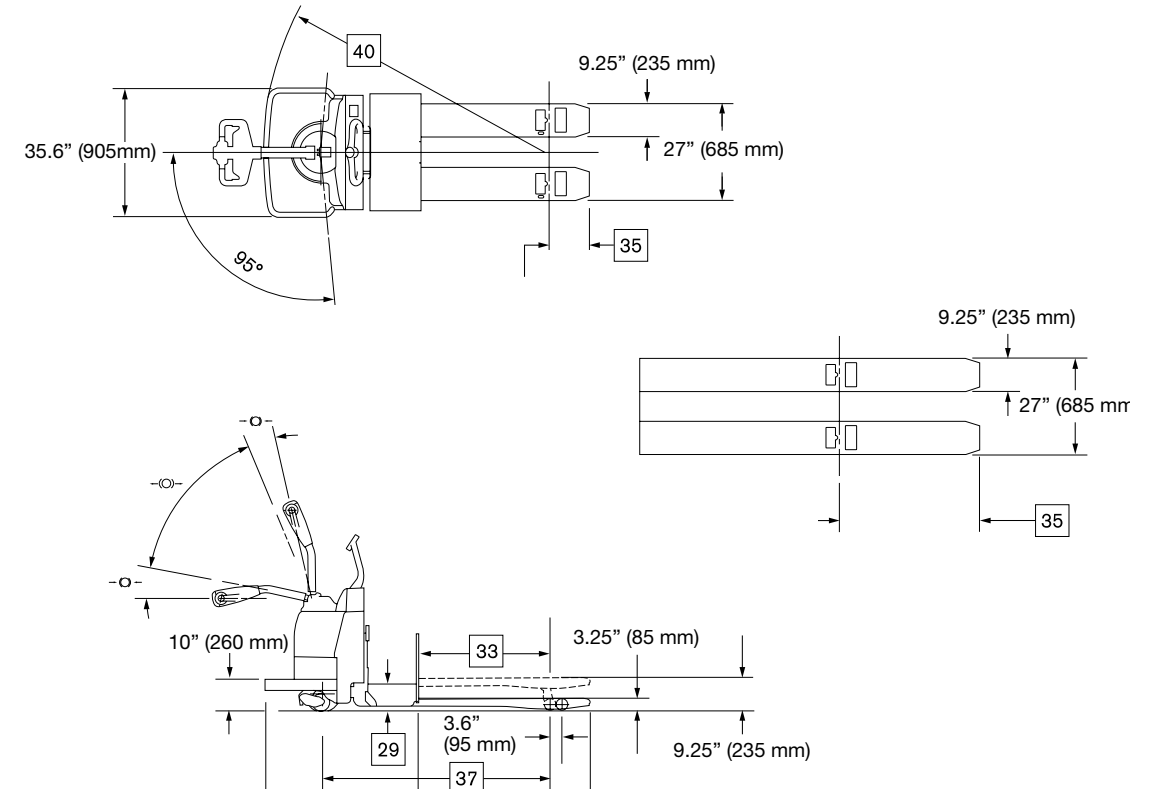

Reliability.

It's the defining trait of our brand and our forklifts.



UniCarriers' roots extend back over 100 years, and over that time, strong, reliable performance has always been the hallmark of our people and our equipment.

Today, our unrivaled reliability continues to provide UniCarriers' customers with a competitive edge. And together, we move the merchandise that moves world commerce with greater efficiency, economy and reliability.

Which brand do you trust?
The one you never have to think about.

We Never Quit.



LogisnextAmericas.com/UniCarriers



UECN0400 04/2026

© 2026 Logisnext Americas Inc. UniCarriers® is a registered trademark of Logisnext Co., Ltd. Logisnext Americas, Inc. reserves the right to make product changes relating to colors, equipment, specifications or available options without notice. For more information, contact your UniCarriers Forklift representative.