

TGX(E) Series



Tow Tractors

24 Volt AC-Powered
10,000 lbs. Capacity

UNICARRIERS
FORKLIFT

NEVER QUIT.

YOUR JOB DOESN'T STOP, AND NEITHER SHOULD YOUR FORKLIFTS.
THAT'S WHERE WE COME IN.

Your application isn't just picking product from aisles upon aisles. There's loading docks, freezers and ramps and moving that product where it needs to go all while operators are constantly getting on and off the trucks for all the daily tasks that keeps business moving.

Flexibility is the name of the game. And that's where the TGX(E) excels.



Power:

24V AC Electric

Maneuverability:

Combines a compact chassis and a tight turning radius

Environment:

Excels in operations that require frequent towing and agility

Travel Distance:

Medium to long distances

Towing:

10,000 lb. capacity

TGX(E) Series In Your Application

Performance, reliability, control, safety and comfort – the TGX(E) incorporates them all to excel in a wide-range of fast-paced industrial applications, such as:

- Distribution & Production
- Warehousing Operations
- General Manufacturing
- Short-term Rentals

ERGONOMICS & COMFORT

Tiller-style, adjustable steer head combined with a cushioned platform and padded compartment provide an impressive workplace to achieve maximum operator comfort and reduced fatigue resulting in sustained productivity. The steer head is adjustable up and down to four set positions to accommodate a variety of user heights and allow for easy battery removal. The steer head's wide, 180° steering arc allows for precise maneuvering in tight spaces with minimal effort.

Ergonomic layout of the truck's control head includes rotary-thumb travel speed controls, which can be operated from either side. Ergonomic placement of travel and horn buttons provides intuitive fingertip control.

Standard coast control allows operator to let the truck coast for more efficient order picking. Hood mounted pick switches are also available as a factory option.

The TGX(E) is designed with a low profile compartment (8.8" platform height), permitting easy entry/exit and walk-through. Its cushioned platform mat provides added comfort.

EFFICIENCY & CONTROL

Advanced motor controller/AC inverter electronically distributes power as needed to the AC drive motor. System offers programmable regenerative neutral braking and proportional plugging. Its AC design eliminates forward and reverse contactors, with electronic travel speed control for precise, efficient performance.

An optional multi-function LCD includes two hour meters and Personal Identification Number (PIN) codes to restrict truck access for greater fleet control. It provides access to customized performance settings and displays a battery discharge indicator with graphic representation of the remaining battery charge. The optional feature also offers on-board diagnostics and troubleshooting without the need for a separate hand tool.

AUTOMATIC JAW COUPLER

The standard heavy-duty automatic jaw coupler is equipped with a foot operated release pedal, located inside the operator compartment. Optional couplers are also available.

Electrical braking system uses regenerative motor torque prior to disc brake actuation, for less component wear and longer life. The spring-applied/ electronically released disc brake system eliminates the need for adjustments. The service/parking brake can be activated by pressing either brake button on the steer head.

LITHIUM-ION BATTERY POWER OPTIONS AVAILABLE

Smart power solutions are designed to communicate directly with the truck for increased efficiency and results. Maintenance-free, which reduces the total cost of ownership and downtime from traditional lead-acid batteries. Lithium-ion batteries are covered by a 6-year, 3,600-cycle with 75% residual capacity.

EFFICIENT PERFORMANCE & GREATER UPTIME

Heavy-duty 5.2 Hp, brushless, three phase AC drive motor, provides high power and torque to handle tough applications. Motor delivers peak performance throughout the battery range. Longer run times per battery charge are achieved by using less energy per cycle.

TGX(E) includes an IP65 rated sealed controller. Sealed switches and logic boards allow operation in multiple environments including coolers, wet rooms and freezers down to -20°F (-28.9°C).

Digital CAN communication between the controller and steer head uses just four wires in the control handle harness to send multiple signals. Hall Effect speed and acceleration control sensor simplifies maintenance and limits downtime due to its non-contact design with fewer moving parts, and no mechanical wiping action, potentiometers, or heaters. Elimination of directional contactors with enhanced thermal capabilities mean optimum performance and minimal downtime.

DURABLE DESIGNS

The TGX(E) Series is manufactured with a rugged frame for tough applications. Its wide drive and trail wheels offer increased floor surface contact and string guards help prevent debris from getting into axles and bearings. Powder coat paint, inside and out, delivers a durable, high gloss, scratch resistant finish. A quiet, spiral beveled gear drive system with sealed ball bearings provides solid performance with low steer effort.

LOWER OPERATING COSTS

Brushless AC drive motor uses fewer components and requires less maintenance for lower operating costs. Easily accessible, rotation sensing encoder is externally mounted on the drive motor for simplified replacement. Motor and controller feature thermal protection system to slow or shut down truck in response to high temperatures.

Unique steer race and enclosed frame design help keep major components free from debris kicked up by the drive tire for less maintenance and longer life.

Belt driven electrical power steering requires less maintenance cost over a chain driven system. By using a belt drive, this enables less frequent service intervals compared to a chain driven system. The belt is checked and adjusted with a simple, single bolt tensioning mechanism, requiring no lubrication or additional cleaning.

One-piece cover with two-bolt removal makes access to the drive unit, and major components quick and easy. Five nut removal of the drive tire simplifies replacement when needed. All lubrication fittings are easily accessible with the truck upright and the battery in place.

Electrical braking system uses regenerative motor torque prior to disc brake actuation, for less component wear and longer life. The spring-applied/ electronically released disc brake system eliminates the need for adjustments.



DIMENSIONS

TGX20B

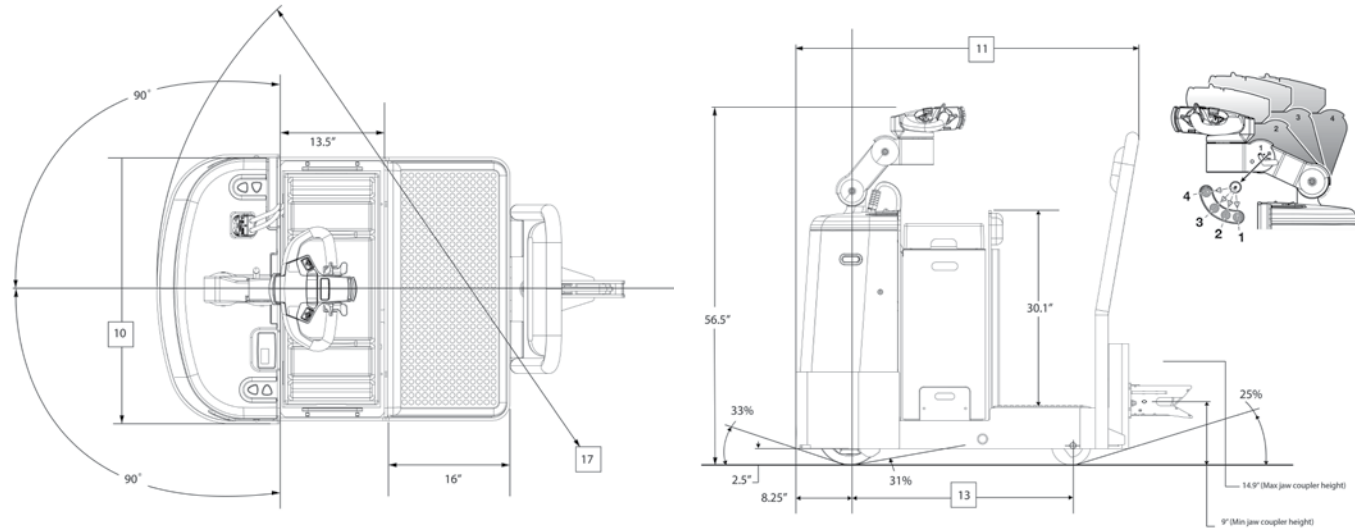

TGX20B

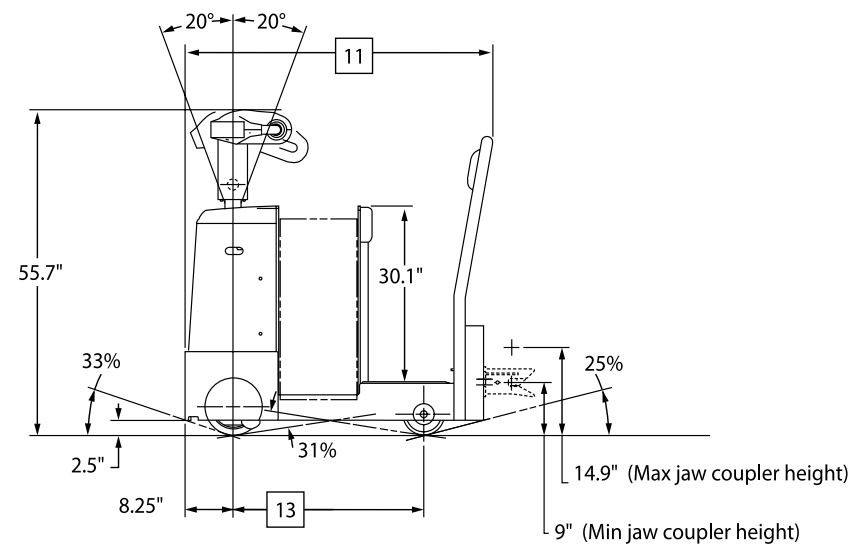
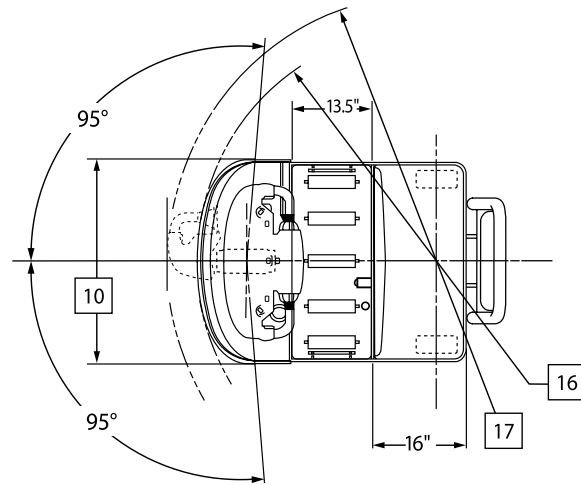

Specifications



MAIN TRUCK SPECIFICATIONS

CHARACTERISTICS	1 Manufacturer's Name		UniCarriers	UniCarriers	
	2 Model	Model designation	TGX20B	TGX20B	
	3	Long model code	TGXT2W4G20BV	TGX2W4G20V	
4	Rolling Load Capacity	lb (kg)	10,000 (4535)	10,000 (4535)	
5	Power Type	Electric	24v	24v	
6	Operator Type	Stand-up	Walkie / Rider	Walkie / Rider	
7	Tire Type	Drive tire	Solid Rubber	Solid Rubber	
8	Trail wheels		Poly	Poly	
9	Wheels	Drive / trail (x=driven)	1x / 2	1x / 2	
DIMENSIONS	10 Overall Dimensions	Width	in (mm)	35.1 (890)	
	11	Length (less coupler)	in (mm)	52.8 (1340)	
	12	Height - to top of steer head	in (mm)	55.7 (1415)	
	13	Wheelbase	in (mm)	32.7 (830)	
	14	Front Overhang	in (mm)	8.25 (210)	
	15	Grade Clearance	Under chassis %	31	
	16	Turning Radius	Minimum outside	in (mm)	41.0 (1040)
	17		Including handle (at 90°)	in (mm)	46.3 (1175)
	18	Tires / Wheels	Drive tire - diameter x width	in (mm)	10 x 4 (255 x 100)
	19		Trail wheels - diameter x width	in (mm)	7 x 3 (180 x 75)
SPEED	20	Truck weight	No load, without battery	lbs (kg)	1195 (545)
	21	Speed - Travel	No load	mph (kph)	9.1 (14.6)
	22		Full load	mph (kph)	5.6 (9.0)
	23	Drawbar Pull	Normal	lb (N)	225 (1000)
24		Maximum	lb (N)	710 (3158)	
BATTERY	25	Compartment Size*	Length x Width x Height	in (mm)	33.3 x 13.5 x 31.6 (850 x 345 x 805)
	26	Amp Hr Capacity	Max (6-hr)	Ah	840
	27	Weight	Min / Max	lb (kg)	855 / 1500 (390 / 680)
	28	Lead Length	Position "B"	in (mm)	20 (508)
	29	Connector	type		SB-175 Red
	30	Battery Roller (Option)	Height from floor (forks lowered)	in (mm)	7.05 (180)

*Battery compartment size with optional rollers and side gates: 30.9 x 13.5 x 31.6 (785 x 345 x 805)

ADJUSTABLE COUPLER PLATES

Coupler plate allows each type of coupler to be adjustable in 1" increments

Type		Coupler Heights	
		Minimum	Maximum
Jaw Coupler	in (mm)	9.0 (228)	14.9 (380)
Tow Eye	in (mm)	9.3 (236)	15.3 (387)
Pin & Clevis	in (mm)	7.3 (186)	13.3 (337)

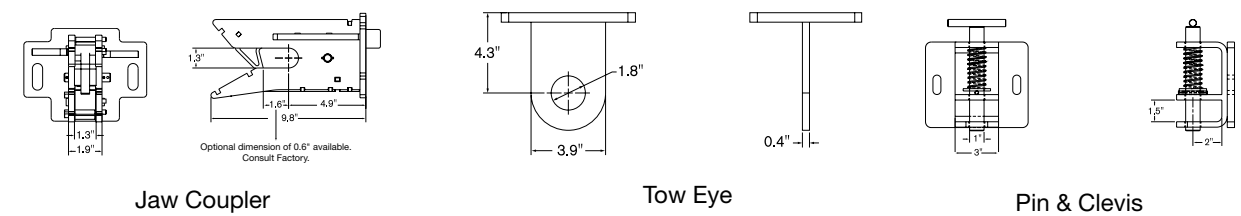
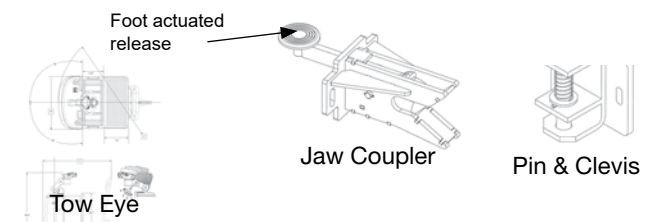

Reliability.

It's the defining trait of our brand and our forklifts.



UniCarriers' roots extend back over 100 years, and over that time, strong, reliable performance has always been the hallmark of our people and our equipment.

Today, our unrivaled reliability continues to provide UniCarriers' customers with a competitive edge. And together, we move the merchandise that moves world commerce with greater efficiency, economy and reliability.

Which brand do you trust?
The one you never have to think about.

We Never Quit.



LogisnextAmericas.com/UniCarriers



UECN0404 04/2026

© 2026 Logisnext Americas Inc. UniCarriers® is a registered trademark of Logisnext Co., Ltd. Logisnext Americas, Inc. reserves the right to make product changes relating to colors, equipment, specifications or available options without notice. For more information, contact your UniCarriers Forklift representative.