

SCX N2 Series



**Stand-up
Counterbalance**

36 Volt AC Cushion Tire
3,000 – 4,000 lbs. Capacities

UNICARRIERS
FORKLIFT

NEVER QUIT.

YOUR JOB DOESN'T STOP, AND NEITHER SHOULD YOUR FORKLIFTS.
THAT'S WHERE WE COME IN.

Your application isn't just picking product from aisles upon aisles. There's loading docks, freezers and ramps and moving that product where it needs to go all while operators are constantly getting on and off the trucks for all the daily tasks that keeps business moving.

Flexibility is the name of the game.
And that's where the SCX N2 excels.

Power: 36V AC Electric

Maneuverability: Excels at tight corners and areas where some sit-down trucks struggle

Environment: An indoor truck built for the rougher floors of loading docks and ramps

Travel Distance: Long or short, and made for frequent on/off

Lift: Max fork height of 276" in.



SCX N2 Series In Your Application

Performance, reliability, control, safety and comfort – the SCX N2 incorporates them all to excel in a wide-range of fast-paced industrial applications, such as:

- Distribution & Production
- Warehousing Operations
- General Manufacturing
- Short-term Rentals

Performance: YOUR APPLICATION DESERVES BOTH POWER AND EFFICIENCY.



Smooth Moves

The SCX N2 can turn within its own footprint for unsurpassed maneuverability. A compact wheelbase and two individually controlled AC motors make short work of tight turns.

3 Customizable Performance Modes = Greater Productivity

Optimize performance based on the application, work environment or operator experience with three factory-set modes to easily customize your lift truck to your business. Or further customize any or all of those 3 settings to create your own precise mix of power and control.

Peak Performance

Quick acceleration, higher productivity, low energy consumption and industry-leading travel and lift speeds - that's what you can expect from the SCX N2. All this comes from specially designed AC motors matched with a controller that's tuned to their precise torque and power curves.

Travel Speeds

8.0/8.0
MPH

Full load / No load

Lift Speeds

83/118
FPM

Full load / No load

Gradeability

15 %

Loaded at 1mph

What do these numbers mean?
Faster cycle times and more productive operations.

Capacity Retention

The SCX N2 offers superior capacity retention at height.

Extended Runtimes

Run 16 hours on a single charge. Our energy efficiency equates to less charging, less changing batteries, less pausing the work day - all without sacrificing the power you need.

Industry-Leading Efficiency

Efficiency does not have to come at the expense of power and performance. With advanced regenerative technology, adjustable auto-power-off and on-demand power steering the SCX N2 series is designed for the long haul.

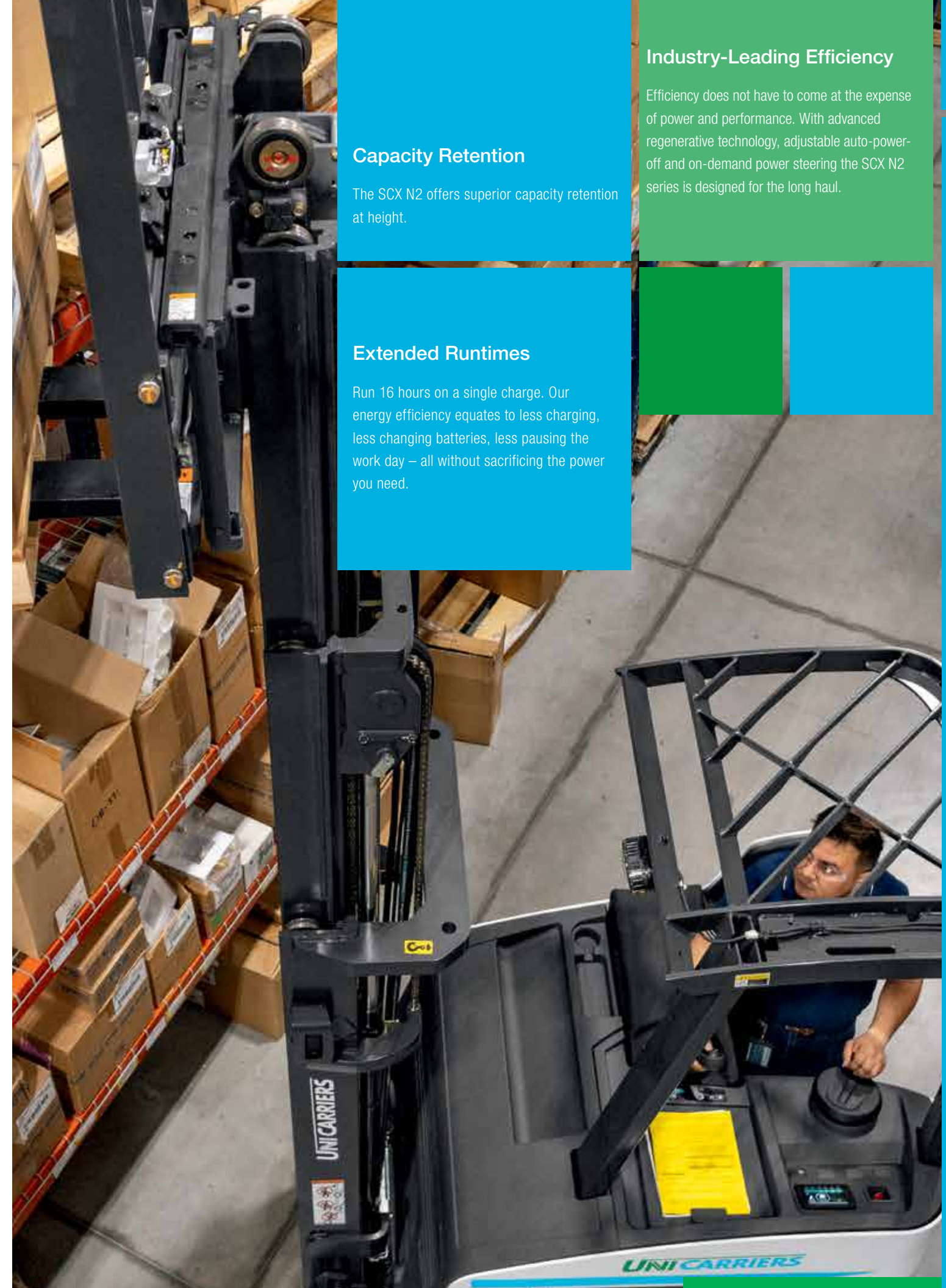

Reliability:

YOUR FORKLIFT NEEDS TO BE READY WHEN YOU NEED IT. UPTIME IS NOT OPTIONAL.

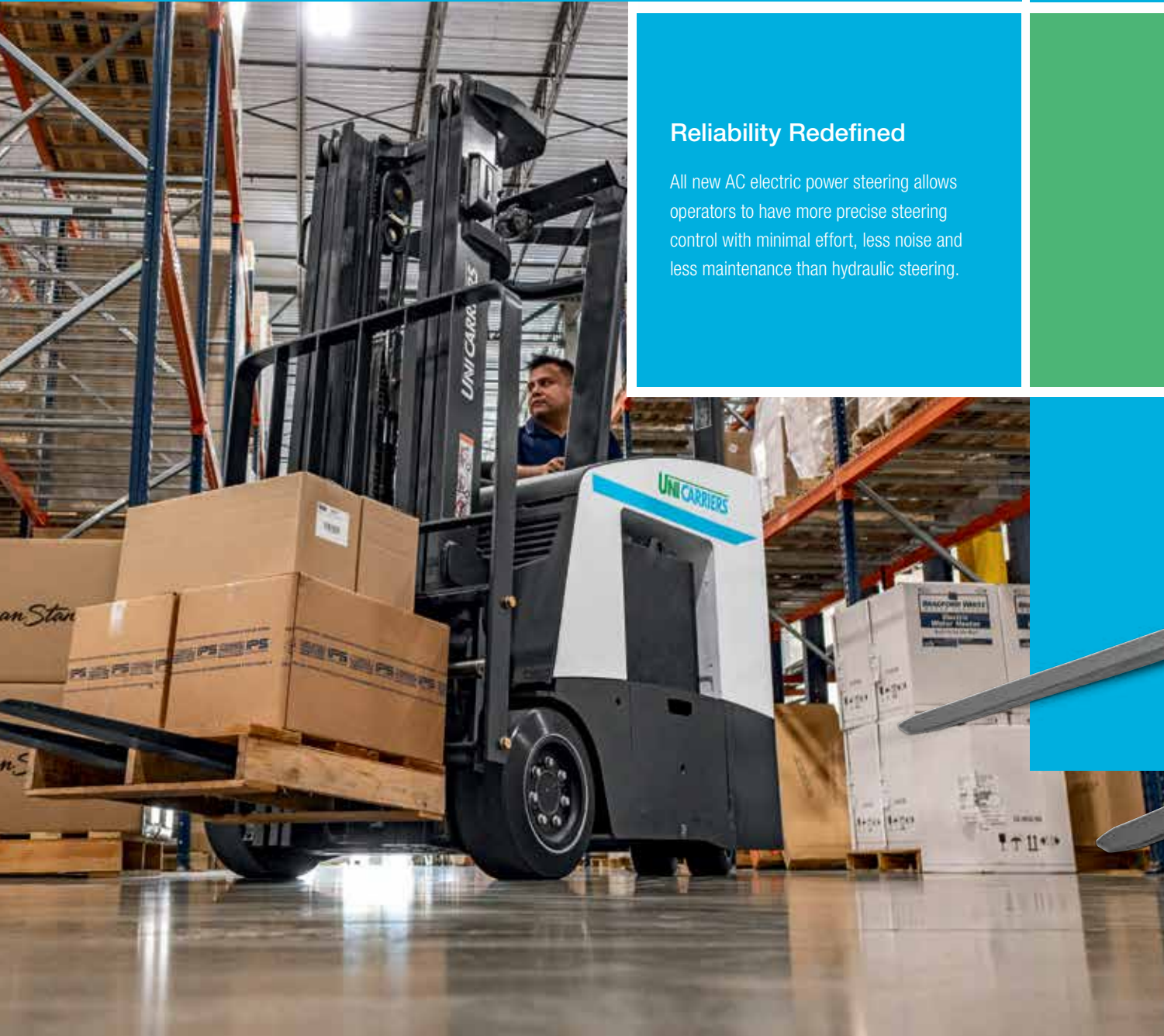

Reliability Redefined

All new AC electric power steering allows operators to have more precise steering control with minimal effort, less noise and less maintenance than hydraulic steering.



Reduced Downtime through On-Board Diagnostics

A robust CAN-Bus network continuously monitors operating systems and immediately alerts the operator via the 4" full-color display for faster troubleshooting.



Dependable AC Drive Units

The synching of our 6th generation AC induction motors with a simple, yet effective, transmission design, results in less complexity, fewer parts and reduced maintenance.

Low Maintenance

Extended major service intervals of 1,000 hours mean more uptime with less time, effort and money expended on maintenance.

Quick Access

Maintenance is quick and easy with removable top and front panels.

Stay Cool

Built-in thermal protection helps safeguard the motor and controller by sending a warning, followed by automatically reducing travel and lift functions to help prevent any costly repairs.

2-Year Unlimited Hour Warranty

The SCX N2 is covered. Ask for details about its 2-Year unlimited hour warranty.

Control:

YOUR PRODUCTS DESERVE PURE PRECISION.
WE PUT IT AT YOUR FINGERTIPS.

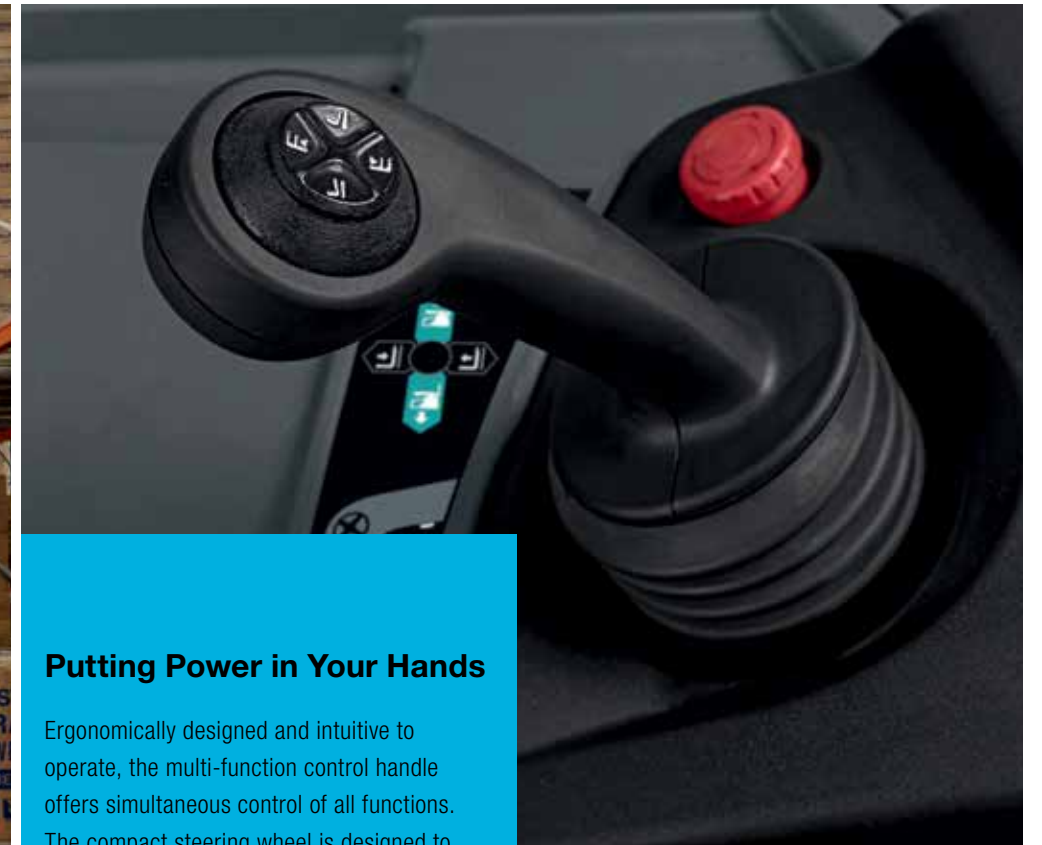

Putting Power in Your Hands

Ergonomically designed and intuitive to operate, the multi-function control handle offers simultaneous control of all functions. The compact steering wheel is designed to not encroach on the operator compartment during turning.



Intelligent Curve Control

The SCX N2 Series control system is constantly monitoring the steering angle and speed of the truck and automatically reduces travel speeds when cornering too quickly.

Ramp Hold

If the travel control is returned to neutral while traveling on a ramp, the controller will reduce and stop movement down the slope.

Safety:

YOUR STAND-UP COUNTERBALANCE SHOULD PROTECT ITS OPERATOR, ITS LOAD AND ITSELF.

Automatic Steer Centering

This feature returns the drive tire to the forward position when the truck is powered on or off, helping to prevent the unit from jogging to the left or right upon startup. This can help reduce HSE risks if someone is standing next to the truck.



Operator Presence

The SCX N2 floorboard has two pedals and an anti-slip ergonomic floormat:

The traction pedal (left) is required for drive functions and allows you to travel forward and reverse.

The presence pedal (right) is required for all functions – hydraulic and travel.

The floorboard keeps the operator's feet in a safe operating position beneath the lip of the entry.

If both pedals are NOT depressed, the truck will be not travel in any direction, helping to keep both the operator and the surroundings safe.

IP Rated Components

With an IP65 rated controller and connectors, and all additional electrical components rated to IP54 minimum, the truck is well protected against dust, water and other debris.

129% Less Deflection Than Leading Competitors

In most deflection testing with competitor trucks, where the amount of right and left sway is measured with a load at height, the SCX N2 has proven to have up to 129% less deflection, boosting operator confidence in this truck.

Maximizing Visibility

The side stance position and chassis-first design result in great visibility in all directions. Additionally, the overhead guard slats and support beams are designed to minimize visual obstructions.

Auto Park

The parking brake is automatically applied when travel speed is at 0 mph and no directional command has been given — or when power to the truck is off.

Bright Idea

Two forward work lights come standard on the SCX N2 series. Ask about additional lighting packages.

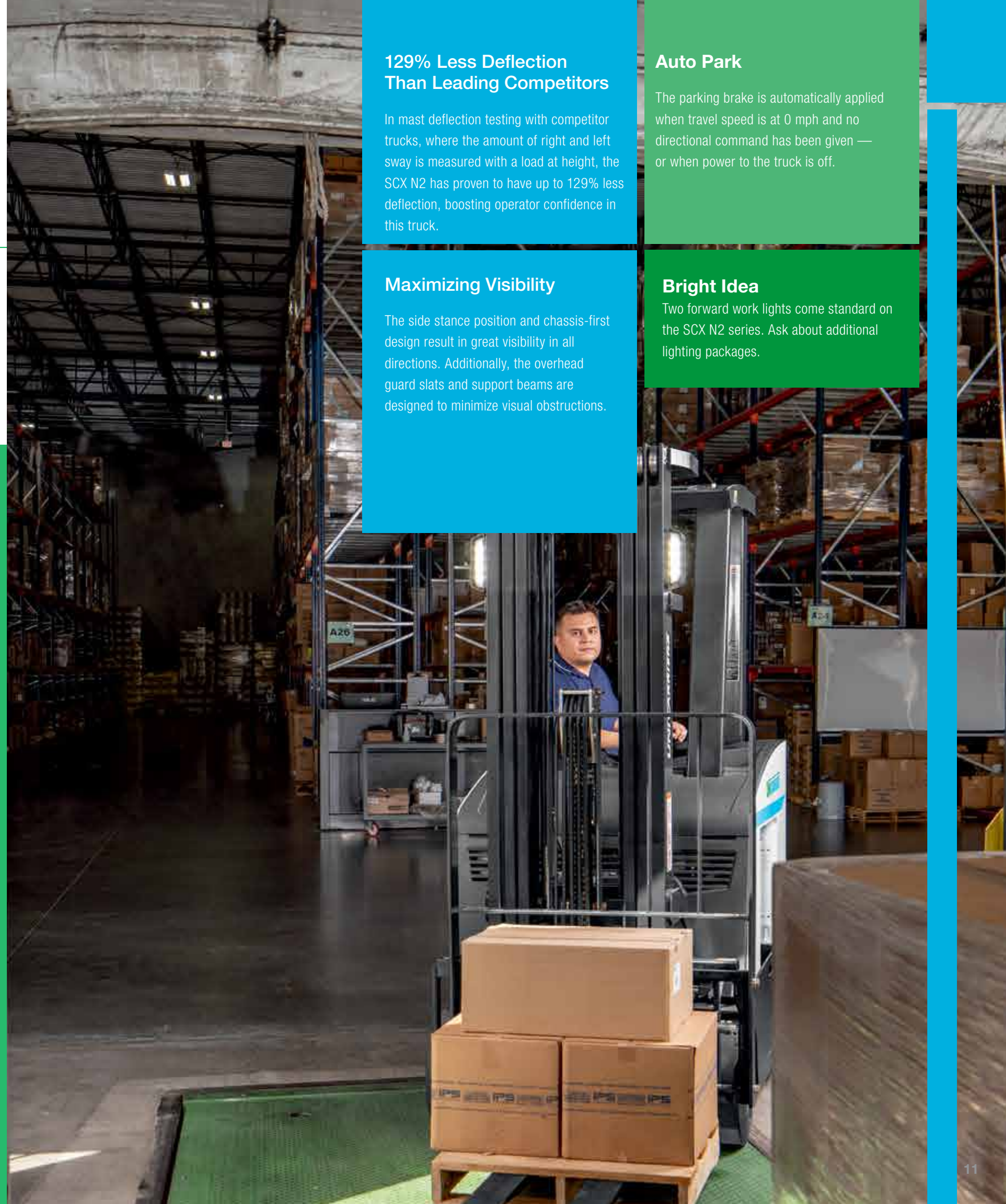

Comfort: YOUR OPERATOR SHOULD BE AS PRODUCTIVE AT THE END OF THE SHIFT AS AT THE BEGINNING.



Electronically-adjustable armrest and backrest

The padded armrest and 60" backrest are electronically adjustable by up to 4" to accommodate operators of different sizes.

Integrated Control Handle

The SCX N2 control handle is integrated into the armrest and adjusts simultaneously with the armrest and backrest for superior ergonomic positioning.

Plush Surroundings

The operator compartment features a padded and adjustable armrest and backrest, in addition to knee and waist padding for 270° cushioning to prevent discomfort and fatigue.

A Smooth Ride

Unlike most competitive forklifts, the platform of the SCX N2 is spring-loaded and dampened, to provide a suspended compartment that is easily customizable to each operators weight and preference.

Easy Entry

The SCX N2 has a low, 9.4" step height along with a wide compartment entry – an ideal design for operators who are constantly getting on and off the truck.

We offer a complete menu of additional options that allow you to customize your forklift to fit your specific workplace environment, operations and business objectives. This is only a small portion of what we offer, so if you don't see what you're looking for here, call your authorized dealer for more options.

Customizations For Your Unique Applications



Lighting Packages

From overhead lights to blue spotlights and more, there are options for even the darkest applications.



Freezer Package

Our freezer packages allow for continuous truck operations in temperatures down to -40°F.



Lower Overhead Guard

Low 83.3" profile for more confined, height-restricted areas. Other heights available.



Battery Gate Interlock Switch

Prevents truck travel if the battery gates are not installed correctly. Operator is notified through an error code on the meter panel.



Side Shifter

Operators will experience greater efficiency due to fewer required moves when storing and retrieving loads. Integral or hang-on designs available.

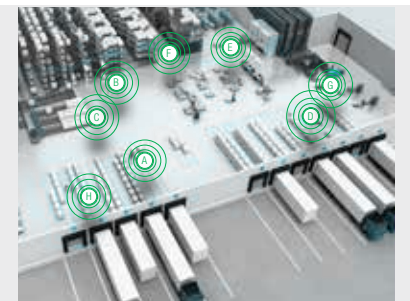

Telematics

3rd party connection point with designated pin-Lift Link Telematics

Specifications

CHARACTERISTICS		SCX30N2-36V		SCX35N2-36V		SCX40N2-36V			
0	Model								
1	Load capacity at rated load center	lb	kg	3,000	1,364	3,500	1,591	4,000	1,818
2	Rated load center – distance from fork face	in	mm	24	600	24	600	24	600
3	Power voltage			36V AC electric		36V AC electric		36V AC electric	
4	Tire type – drive / steer			solid rubber / poly		solid rubber / poly		solid rubber / poly	
5	Wheels – number front / rear (x=driven)			2x / 2		2x / 2		2x / 2	
DIMENSIONS									
6	Maximum fork height – standard triplex mast	in	mm	188	4,775	188	4,775	188	4,775
7	Free fork height – standard triplex mast	in	mm	35	889	35	889	35	889
8	Fork width	in	mm	3.9	100	3.9	100	3.9	100
9	Fork thickness	in	mm	1.4	35	1.4	35	1.6	40
10	Fork spacing – out-to-out (min.)	in	mm	9.5	240	9.5	240	9.5	240
11	Fork spacing – out-to-out (max.)	in	mm	36.5	920	36.5	920	36.5	920
12	Tilt angle – forward / backward	degree		3 / 5		3 / 5		3 / 5	
13	Mast width	in	mm	22	570	22	570	22	570
14	Length to fork face	in	mm	63.0	1,601	65.0	1,652	70	1,778
15	Overall chassis width	in	mm	41	1,041	41	1,041	41	1,041
16	Overall lowered height (mast)	in	mm	82.9	2,105	82.9	2,105	82.9	2,105
17	Overall lowered height to top of overhead guard	in	mm	88.0	2,240	88.0	2,240	88.0	2,240
18	Overall height with extended mast	in	mm	236.6	6,009	236.6	6,009	236.6	6,009
19	Step height	in	mm	9.4	240	9.4	240	9.4	240
20	Battery roller height	in	mm	7.0	178	7.0	178	7.0	178
21	Load moment constant ²⁾	in	mm	12.2	310	12.2	310	12.2	315
22	Minimum outside turning radius ³⁾	in	mm	50.8	1,291	52.8	1,342	57.8	1,469
23	Minimum aisle width 90° stack – zero clearance ¹⁾	in	mm	turning radius + load moment constant + load length + aisle clearance					
PERFORMANCE									
24	Travel speed – loaded / empty	mph	km/h	8 / 8	12.9 / 12.9	8 / 8	12.9 / 12.9	8 / 8	12.9 / 12.9
25	Lift speed – loaded (triplex) (mast lift)	fpm	m/s	83	0.42	83	0.42	83	0.42
26	Lift speed – empty (triplex) (mast lift)	fpm	m/s	118	0.60	118	0.60	118	0.60
27	Lower speed – loaded (triplex)	fpm	m/s	102	0.52	102	0.52	102	0.52
28	Lower speed – empty (triplex)	fpm	m/s	98	0.50	98	0.50	98	0.50
29	Gradeability – loaded (maximum) at 1 mph / 1.6 km/h		%	15		15		15	
30	Gradeability – empty (maximum) at 1 mph / 1.6 km/h		%	15		15		15	
WEIGHTS									
31	Truck weight – empty with minimum weight battery	lb	kg	8,424	3,829	8,424	3,829	9,244	4,202
32	Battery weight (minimum)	lb	kg	1,700	773	2,000	909	2,600	1,182
33	Battery weight (maximum)	lb	kg	2,000	909	2,300	1,045	2,900	1,318
WHEELS / CHASSIS									
34	Chassis type (stand / sit)			stand-up		stand-up		stand-up	
35	Wheelbase ⁴⁾	in	mm	41.7	1,059	43.7	1,110	48.7	1,237
36	Ground clearance – center of wheelbase	in	mm	4.0	102	4.0	102	4.0	102
37	Ground clearance – lowest point at mast	in	mm	3.0	76	3.0	76	3.0	76
38	Tire size – drive	inches		16 x 7 x 10.5		16 x 7 x 10.5		16 x 7 x 10.5	
39	Tire size – steer	inches		10 x 5 x 6.5		10 x 5 x 6.5		10 x 5 x 6.5	
40	Brake type			electromagnetic disc		electromagnetic disc		electromagnetic disc	
ELECTRICAL									
41	Traction motor type			AC induction		AC induction		AC induction	
42	Traction motor output kW (60 minutes rating)	HP	kW	5.4 (x2)	4.0 (x2)	5.4 (x2)	4.0 (x2)	5.4 (x2)	4.0 (x2)
43	Pump motor type			AC induction		AC induction		AC induction	
44	Pump motor output kW (15% rating)	HP	kW	17.4	13.0	17.4	13.0	17.4	13.0
45	Steer motor type			AC induction		AC induction		AC induction	
46	Steer motor output kW (60 minutes rating)	HP	kW	0.9	0.7	0.9	0.7	0.9	0.7
47	Battery – maximum capacity – A/H (6 hour rating)		Ah	1,240		1,240		1,240	
48	Battery compartment length (front - back)	in	mm	14.25	362	16.25	413	21.25	540
49	Battery compartment width (side - side)	in	mm	38.50	978	38.50	978	38.50	978
50	Battery compartment height	in	mm	32.00	813	32.00	813	32.00	813

Option Availability

VEHICLE MANAGEMENT		
AC traction and hydraulic control system		●
Dual AC traction motors		●
AC electric power steering		●
Infinitely variable hydraulic control		●
On-board diagnostics, self test and service history		●
Low battery lift interrupt system		●
BATTERY / ELECTRICAL		
Battery compartment rollers and side gates		●
36V Lithium battery preparation		○
36V Lithium-Ion chargers		○
36V Lithium battery - various options		○
Battery retainer interlock		○
BRAKE		
Advanced regenerative braking		●
Electro-magnetic parking brake		●
Parking brake indicator		●
MAST / CARRIAGE / SIDESHIFTER / FORK POSITIONER		
Auto mast lock system		●
Low overhead guard		○
83" Overhead guard (Drive in rack configuration)		○
91" Overhead guard (Drive-in rack configuration)		○
Two mast-mounted LED worklights		●
OPERATOR CONVENIENCES		
Premium color operator display		●
Knee, back & armrest padding		●
Low 9.4" step height		●
Electric tilt cushioning and leveling		○
Customizable tilt speeds at all heights		●
Forward steering		●
Reverse steering		○
OPERATOR COMFORT		
Simultaneous multifunction control handle		●
Anti-fatigue floor board		●
Multiple weight adjustment settings		●
Height adjustable armrest and backrest electrically controlled		●
Operator backrest extension 60"		●
Drive-In rack low operator backrest - 50"		○
ACCESSORIES		
Operator mirror		○
Operator compartment fan		○
USB Port (qty. 1) - Single 5V power supply		○
USB Port (qty. 2) - Double 5V power supply		○
OHG accessories		○
Accessory mounting bracket		○
RF scanner holder		○
Computer mount arm		○

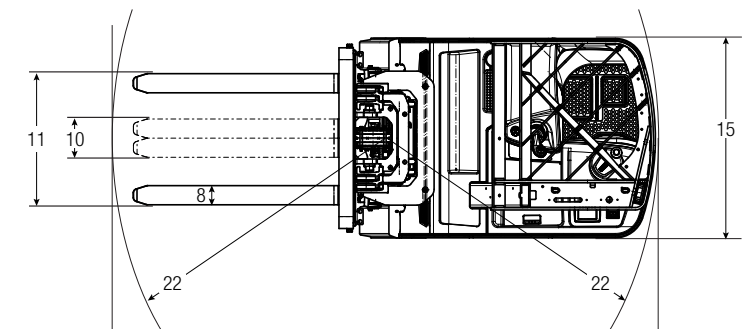
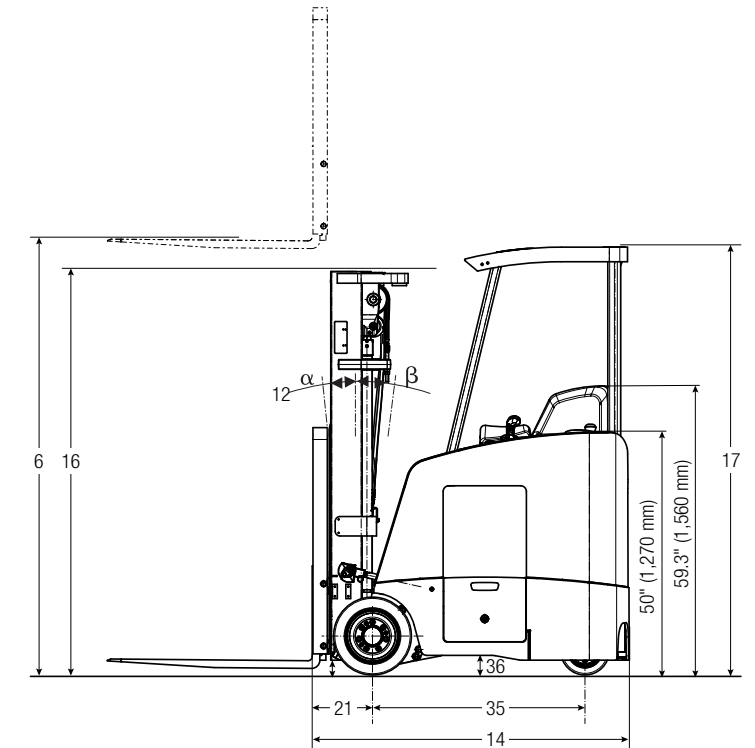

This specification sheet only provides technical values for the standard truck. Non-standard tires, different masts, additional equipment, etc., could produce other values. Rights reserved for technical changes and improvements.

Equipping these models with a power source (e.g. Lithium-ion, Hydrogen Fuel cell, etc.) that has not been previously approved by the factory is considered a modification. Per OSHA 1910.178 and ANSI/ITSDF B56.1, please consult with your factory representative prior to installing any non OEM power source that has not been previously approved.

● Standard ○ Optional

- 1) Add load length and operator clearance
- 2) Add 2.25" (57.0 mm) for quad masts; add 2.50" (63.5 mm) for hang-on side shifter / hang-on fork positioner options; Add 1.00" (25.4 mm) for integrated sideshifter
- 3) Turning radius: battery compartment 14.25" = 50.8" (1,291 mm); battery compartment 16.25" = 52.8" (1,342 mm); battery compartment 18.25" = 54.8" (1,393 mm); battery compartment 21.25" = 57.8" (1,469 mm)
- 4) Wheelbase: battery compartment 14.25" = 41.7" (1,059 mm); battery compartment 16.25" = 43.7" (1,110 mm); battery compartment 18.25" = 45.7" (1,161 mm); battery compartment 21.25" = 48.7" (1,237 mm)

Reliability.

It's the defining trait of our brand and our forklifts.



UniCarriers' roots extend back over 100 years, and over that time, strong, reliable performance has always been the hallmark of our people and our equipment.

Today, our unrivaled reliability continues to provide UniCarriers' customers with a competitive edge. And together, we move the merchandise that moves world commerce with greater efficiency, economy and reliability.

Which brand do you trust?
The one you never have to think about.

We Never Quit.



LogisnextAmericas.com/UniCarriers



UECM0401 05/2026

© 2026 Logisnext Americas Inc. UniCarriers® is a registered trademark of Logisnext Co., Ltd. Logisnext Americas, Inc. reserves the right to make product changes relating to colors, equipment, specifications or available options without notice. For more information, contact your UniCarriers Forklift representative.