

TCM

FB15-FB35

ELECTRIC COUNTERBALANCE FORKLIFT TRUCK



1.0 – 3.5 tons

Class-1 Sit-down type

BEYOND THE LIMITS

This series comes with a cool, exciting body design, and it is equipped with the full complement of functions and the ease of operation that lots of users are looking for. These trucks provide solutions to meet operators' requirements. This comes with the reliable quality and the increased efficiency as well as productivity in the operating site. These electric powered models include 1.0-3.5 ton trucks.



FB SERIES

1.0 – 3.5 tons

ELECTRIC COUNTERBALANCE FORKLIFT TRUCK
Class-1 Sit-down type





Reliability and Control

Automatic Torque Increase

When starting up a ramp or moving with a heavy load on the forks, the automatic torque increase function automatically detects the weight of loads on the forks and increases the output of the traction motor appropriately, allowing easier starts, especially when going up a ramp.

Operation Interlock System

If the operator is not on the seat or leaves the operator's compartment, the Operation Interlock System is activated to lock the travel and load handling operations of the truck. This safety system prevents unintended movement if the operator of the truck is not in the correct driving position or a control is moved unintentionally when the operator is not in the seat.



Adjustable Operating Characteristics

The operator can select the most suitable operating mode, for traveling or load handling, to suit their driving skills and the working conditions.

Customizing the Operating Characteristics

The driving or load handling characteristics can be finely tuned according to the operator's skills and the working conditions. The truck is designed with flexibility to respond to both agile operation by experienced operators and slower operation by inexperienced operators.

Dependability Built In

Warehouse work can be tough, and you need a machine you can rely on, through good times and bad. These trucks are designed to be rugged, reliable performers that give operators more performance - with less hassle and maintenance.

- Better Efficiency with an AC Motor: High-quality AC motor drives these trucks, delivering smooth rides, faster acceleration and greater responsiveness - while optimizing the lifespan of your lift trucks battery and keeping maintenance requirements low.
- IPX4 Waterproofing: Whether in a warehouse or in the rain, you can count on these trucks to keep running reliably, thanks to IPX4 waterproofing.

The exterior of this series adds functional beauty which supports daily load handling operations at worksites. These trucks are packed with ergonomic improvements, including:

- Excellent forward and rearward visibilities
- Assist grips and large steps for easy entry and exit of the truck
- Operator compartment for efficient and comfortable operation, with sufficient overhead clearance
- Low center of gravity for excellent stability during turning
- Counterweight reconfigured to follow a subtle curve that does not interfere with the operator's rear visibility, which provides direct visibility to obstacles in the aisle

In addition, these trucks provide outstanding basic truck performance, allowing easier load handling operations.

Additional comfort features include:

Excellent Visibility – The all-around view is superb by the design of the overhead guard, the load backrest and the counterweight shape. This excellent visibility positively contributes to work efficiency and safety for the operator.

Easy Access – This series has a low mounting step as well as a convenient assist grip, with sufficient overhead clearance for smooth entry. The operator will enjoy this safe and quick easy-on & easy-off configuration.

Rear Assist Grip (With Horn) – The seating arrangement with rear assist grip helps ensure the operator can maintain a comfortable driving position while moving in reverse, without having an awkward posture. This rear assist grip has an integrated warning horn to alert workers around when the truck is moving backwards.

Increased Operator Awareness

Other awareness features that operators will appreciate include an easily accessible and unobstructed emergency stop button, a highly visible optional orange seatbelt, and optional password system that restricts the access and operation of the truck to authorized personnel.

Maximum Travel Speed Function

- Switching to "Turtle" speed: Sets the maximum travel speed to the value specified by the operator.
- Limiting maximum speed: Controls travel speed so the truck does not exceed the upper limit preset.



Comfort and Safety



Specifications

CHARACTERISTICS									
0	Model		FB15P9	FB18P9	FB20P9	0	FB25P9	FB30P9	FB35P9S
1	Rated Capacity	kg	1,500	1,750	2,000	1	2,500	3,000	3,500
2	Load Center	mm	500	500	500	2	500	500	500
3	Motor Type		AC	AC	AC	3	AC	AC	AC
4	Operator Type		Seated	Seated	Seated	4	Seated	Seated	Seated
DIMENSIONS									
5	Lift Height	mm	3,000	3,000	3,000	5	3,000	3,000	3,000
6	Free Lift	mm	115	115	145	6	145	140	140
7	Tilt Angle	deg	7 / 11	7 / 11	7 / 11	7	7 / 11	7 / 11	7 / 11
8	Carriage - Class II, III	mm	Class II	Class II	Class II	8	Class II	Class III	Class III
9	Fork Dimensions – T / W / L	mm	35 x 100 x 1,070	35 x 100 x 1,070	45 x 100 x 1,070	9	45 x 100 x 1,070	45 x 122 x 1,070	45 x 122 x 1,070
10	Fork Spread (max. / min.)	mm	920 / 240	920 / 240	975 / 240	10	975 / 240	995 / 280	995 / 280
11	Overall Length	mm	3,150	3,190	3,375	11	3,415	3,575	3,670
12	Length To Fork Face	mm	2,080	2,120	2,305	12	2,345	2,505	2,590
13	Overall Width	mm	1,100	1,115	1,155	13	1,155	1,255	1,255
14	Height - Mast Lowered	mm	1,990	1,990	1,995	14	1,995	2,015	2,115
15	Height – Mast Extended	mm	4,055	4,055	4,055	15	4,055	4,055	4,055
16	Height of Overhead Guard	mm	2,110	2,110	2,110	16	2,110	2,260	2,330
17	Front Overhang	mm	395	395	445	17	445	485	490
18	Minimum Turning Radius	mm	1,850	1,880	2,030	18	2,215	2,260	2,285
PERFORMANCE									
19	Travel Speed - loaded / unloaded (pneumatic tire)	km/h	14.0 / 16.0	13.5 / 15.5	14.0 / 16.0	19	14.0 / 16.0	13.5 / 15.5	13.5 / 15.5
20	Travel Speed - loaded / unloaded (no-puncture tire)	km/h	13.0 / 15.0	12.5 / 14.5	13.0 / 15.0	20	13.0 / 15.0	12.5 / 14.5	12.5 / 14.5
21	Lifting Speed - loaded / unloaded	mm/s	350 / 540	350 / 540	290 / 470	21	260 / 470	320 / 550	270 / 460
22	Lowering Speed - loaded / unloaded	mm/s	500 / 470	500 / 470	480 / 440	22	480 / 440	450 / 450	450 / 450
23	Maximum Gradeability - 3 min. rating, 1.5km/h +	%	19	17	19	23	16	16	13
WEIGHTS									
24	Service Weight without battery	kg	2,250	2,495	2,960	24	3,335	3,915	4,445
25	Service Weight with battery	kg	2,920	3,165	3,780	25	4,190	5,070	5,600
26	Axle Loading - loaded (front / rear)	kg	3,920 / 500	4,320 / 595	5,090 / 690	26	5,610 / 1,080	7,155 / 915	7,955 / 1,145
27	Axle Loading - unloaded (front / rear)	kg	1,465 / 1,455	1,450 / 1,715	1,850 / 1,930	27	2,030 / 2,160	2,390 / 2,680	2,380 / 3,220
WHEELS / CHASSIS									
28	Tires - number front / rear		2 / 2	2 / 2	2 / 2	28	2 / 2	2 / 2	2 / 2
29	Tire Size - front	mm	6.00-9 Solid	21x8-9 Solid	21x8-9 Solid	29	21x8-9 Solid	28x9-15 Solid	28x9-15 Solid
30	Tire size - rear	mm	5.00-8 Solid	5.00-8 Solid	18x7-8 Solid	30	18x7-8 Solid	6.50-10 Solid	6.50-10 Solid
31	Wheelbase	mm	1,410	1,410	1,520	31	1,520	1,680	1,680
32	Tread - front	mm	930	925	955	32	955	1,030	1,030
33	Tread - rear	mm	900	900	965	33	965	980	980
34	Ground Clearance - at mast	mm	110	110	115	34	115	130	130
35	Ground Clearance - at middle of wheelbase	mm	110	110	110	35	110	120	120
36	Service Brake		2xDrum	2xDrum	2xDrum	36	2xDrum	2xDrum	2xDrum
37	Parking Brake		Mechanical	Mechanical	Mechanical	37	Mechanical	Mechanical	Mechanical
38	Power Steering type		Electro-hydraulic Power Steering	Electro-hydraulic Power Steering	Electro-hydraulic Power Steering	38	Electro-hydraulic Power Steering	Electro-hydraulic Power Steering	Electro-hydraulic Power Steering
ENGINE / TRANSMISSION									
39	Battery type		JIS	JIS	JIS	39	JIS	JIS	JIS
40	Battery Voltage	V/Ah	48 / 415	48 / 415	48 / 510	40	48 / 565	72 / 470	72 / 470
41	Drive Motor - 60 min. rating	kW	7.0	7.0	8.5	41	8.5	11.0	11.0
42	Hydraulic Motor 5 min. rating	kW	9.5	9.5	11.5	42	11.5	15.0	15.0
43	Power Steering Motor - 60 min. rating	kW	1.5	1.5	1.5	43	1.5	1.7	1.7
44	Motor Control		AC Inverter	AC Inverter	AC Inverter	44	AC Inverter	AC Inverter	AC Inverter

Features & Options

Features

GENERAL EQUIPMENT	
Full hydraulic power steering	●
Tilt steering	●
Load backrest	●
Steering synchronizer	●
Speed limit switch	●
Tilt cylinders	●
Meter panel	●
- parking brake warning	●
- seat belt reminder	●
- battery discharge indicator	●
- hour meter	●
Lamps	●
- head lamps	●
- turn signal lamps	●
- rear combination lamps	●
ORS suspension seat	●
Operation interlock system (traction and hydraulics)	●
Overhead guard	●
Floor mat	●
Rear view mirror	●
Back buzzer	●
Rear Assist grip with horn button	●
Operation manual	●

● Standard

* Products and specifications are subject to change without notice.

This specification sheet only provides technical values for the standard truck. Non-standard tires, different masts, additional equipment, etc., could produce other values. Rights reserved for technical changes and improvements.

Equipping these models with a power source (e.g. Lithium-ion, Hydrogen Fuel cell, etc.) that has not been previously approved by the factory is considered a modification. Per ISO 3691-1, please consult with your factory representative prior to installing any non OEM power source that has not been previously approved.

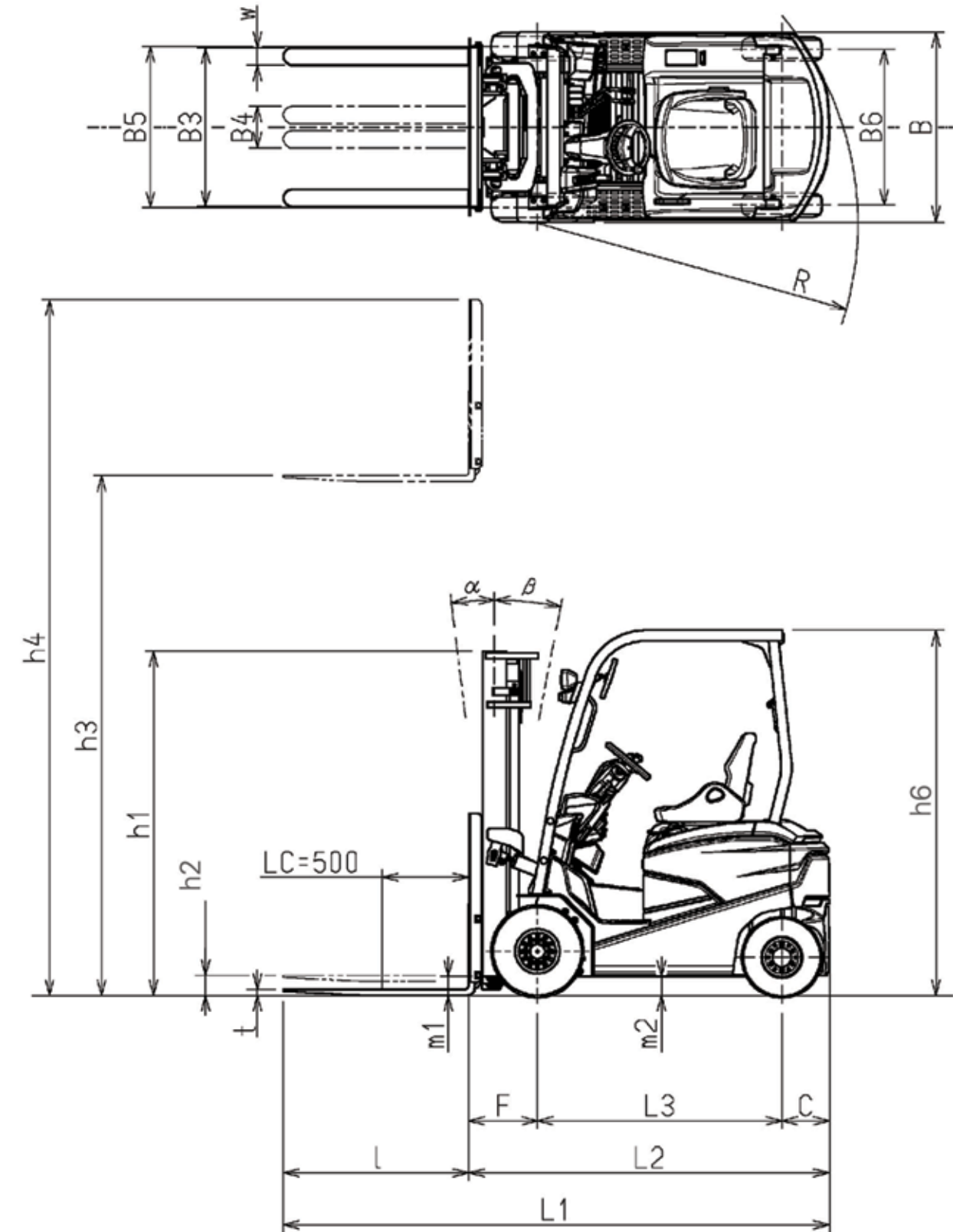

FB15-FB35

ELECTRIC COUNTERBALANCE FORKLIFT TRUCK



TECM0400LA 04-2026 Printed in U.S.A.

© 2026 Logisnext Americas Inc. UniCarriers® is a registered trademark of Logisnext Co., Ltd. UniCarriers Americas Corporation reserves the right to make product changes relating to colors, equipment, specifications or available options without notice. For more information, contact your UniCarriers representative.