

SPECIFICATIONS

PNEUMATIC TIRE FORKLIFT

6-10 tons

HEAVY DUTY

Built to handle tough loads, it's the forklift you need to get the job done.

SPECIFICATIONS

FD60NH
FD70NH
FD80NH
FD100NH

**WHEN
RELIABILITY IS
EVERYTHING...**



 **MITSUBISHI
FORKLIFT TRUCKS**

FD60NH-FD100NH Series IC PNEUMATIC TIRE FORKLIFTS

6-10 ton capacity



Outstanding Performance, Remarkable Value: Mitsubishi Forklift Trucks developed the FB60NH – FB100NH series to provide the power to get through tough jobs day after day – and at great value. From the dependable design to a higher-performance engine, this series is ready to work when you are.

KEY APPLICATIONS

- Lumber
- Stone and glass
- Warehousing
- Manufacturing
- Recycling

SAFETY

- Excellent visibility
- Audible and visual warnings, including a backup alarm, come standard
- A wide carriage provides operators with excellent forward and fork tip visibility
- Dependable design providing a high level of safety

ERGONOMICS

- Spacious operator compartment
- Generous headroom and plenty of foot room
- Logically positioned automotive-style controls
- Small diameter steering wheel
- Seat that reclines and adjusts easily to match its operator's size
- Simplified entry and exit is possible with a convenient hand grip and an extra-wide 3-step entry that includes a non-skid step for sure footing

PERFORMANCE AND DURABILITY

- Exceptional power and performance
- Durable steel frame for rugged applications
- One of the highest lift speeds in its class
- Designed to help deliver maximum uptime even for some of the most demanding jobs
- Low fuel consumption combined with a high-powered engine provides excellent productivity
- Electronic-controlled automatic transmission provides dependable travel control with a single control lever
- In case of an emergency, these trucks are equipped with excellent stopping power
- Simplified maintenance means less downtime – boltless floorboards can be removed and reinstalled quickly and easily without any tools to gain access to the transmission and hydraulics



VDI - PERFORMANCE & DIMENSIONS

CHARACTERISTICS				FD60NH		FD70NH		FD80NH		FD100NH	
1	Capacity at rated load center	lb	kg	13,000	6,000	15,500	7,000	17,500	8,000	22,000	10,000
2	Capacity at load center - Distance	in	mm	24	600	24	600	24	600	24	600
3	Power - electric, diesel, gasoline or LP gas			Diesel		Diesel		Diesel		Diesel	
4	Tire type - cushion or pneumatic			Pneumatic		Pneumatic		Pneumatic		Pneumatic	
5	Wheels (x=driven) - number front / rear			4x / 2		4x / 2		4x / 2		4x / 2	
DIMENSIONS											
6	Maximum fork height (top of fork)	in	mm	118	3,000	118	3,000	118	3,000	118	3,000
7	Free fork height	in	mm	8.1	205	8.5	215	8.1	205	8.1	205
8	Forks - thickness x length x width	in	mm	48.0 x 5.9 x 2.4 1,220 x 150 x 60		48.0 x 5.9 x 2.8 1,220 x 150 x 70		48.0 x 6.7 x 3.0 1,220 x 170 x 75		48.0 x 7.1 x 3.0 1,220 x 180 x 75	
9	Fork spacing - out-to-out minimum / maximum	in	mm	11.8/72.2 300/1,835		11.8/72.2 300/1,835		13.4/78.7 340/2,000		15.9/84.4 465/2,145	
10	Tilt - forward / backward		deg	6 / 12		6 / 12		6 / 12		6 / 12	
11	Length to fork face	in	mm	139.2	3,535	141.7	3,600	155.1	3,940	167.5	4,255
12	Width	in	mm	78.5	1,995	78.5	1,995	85.2	2,165	88.4	2,245
13	Mast height fork lowered	in	mm	98.4	2,500	98.4	2,500	106.3	2,700	112.2	2,850
14	Mast height fork raised	in	mm	174	4,420	174	4,420	174	4,420	170.5	4,330
15	Height - to top of overhead guard	in	mm	96.5	2,450	96.5	2,450	100.8	2,560	100.8	2,560
16	Height - with extended mast	in	mm	174	4,420	174	4,420	174	4,420	170.5	4,330
17	Minimum outside turning radius	in	mm	132.3	3,360	134.6	3,420	142.9	3,630	152.8	3,880
18	Rear overhang	in	mm	27.6	700	30.1	765	29.9	760	28.9	735
19	Load distance (Centerline of front axle to front face of forks)	in	mm	24.2	615	24.6	625	28.3	720	28	710
20	Minimum aisle - 90° stack - zero clearance w/o a load	in	mm	212.4	5,395	214.8	5,455	227.2	5,770	236.6	6,010
PERFORMANCE											
21	Travel speed - loaded / empty	mph	km/h	16.1 / 18.6	26 / 30	16.1 / 18.6	26 / 30	15.5 / 18.6	25 / 30	14.9 / 18.6	24 / 30
22	Lift speed - loaded / empty	fpm	m/s	98.4 / 108.3	500 / 550	90.6 / 108.3	460 / 550	88.6 / 92.5	450 / 470	76.8 / 80.7	390 / 410
23	Lowering speed - loaded / empty	fpm	m/s	88.6 / 98.4	450 / 500	88.6 / 98.4	450 / 500	88.6 / 88.6	450 / 450	92.5 / 66.9	470 / 340
24	Maximum drawbar pull - full / no load	lb	N	12,100 / 4,960	53.9 / 22.1	11,900 / 4,850	52.9 / 21.6	12,900 / 6,150	57.3 / 27.4	12,900	57.3 / 31.4
25	Maximum gradeability - full load at 1mph		%	33		29		27		22	
26	Maximum gradeability - no load		%	19		19		19		20	
WEIGHT											
27	Empty	lbs	kg	19,200	8,710	20,750	9,410	24,580	11,150	27,650	12,540
28	Axle load - with rated load front / rear	lbs	kg	28,770 / 3,660	13,050 / 1,660	31,970 / 4,210	14,500 / 1,910	37,790 / 4,450	17,140 / 2,020	44,620 / 5,050	20,240 / 2,290
29	Axle load - without load front / rear	lbs	kg	8,330 / 10,870	3,780 / 4,930	8,140 / 12,610	3,690 / 5,720	10,800 / 13,780	4,900 / 6,250	12,300 / 15,370	5,580 / 6,970
CHASSIS											
30	Tire Number - front / rear			4 / 2		4 / 2		4 / 2		4 / 2	
31	Tire size - front, standard duals		in	8.25 x 15-14 PR		8.25 x 15-14 PR		9.00 x 20 - 14PR		9.00 x 20 - 14PR	
32	Tire size - rear tires		in	8.25 x 15-14 PR		8.25 x 15-14 PR		9.00 x 20 - 14PR		9.00 x 20 - 14PR	
33	Wheel base	in	mm	90.6	2,300	90.6	2,300	98.4	2,500	110.2	2,800
34	Tread width - front, standard duals	in	mm	57.9	1,470	57.9	1,470	63	1,600	63	1,600
35	Tread width - rear tires	in	mm	66.9	1,700	66.9	1,700	66.9	1,700	66.9	1,700
36	Backrest height	in	mm	53.9	1,370	53.5	1,360	53.3	1,355		Without Backrest 1,100
37	Overhead guard clearance	in	mm	43.3	1,100	43.3	1,100	43.3	1,100	43.3	1,100
38	Drawbar pin center height	in	mm	16.5	420	16.5	420	22.4	570	22.4	570
39	Floor Height	in	mm	36.6	930	36.6	930	40.9	1,040	40.9	1,040
40	Ground clearance - at lowest point at mast	in	mm	7.5	190	7.5	190	9.6	245	9.6	245
41	Ground clearance - at center of wheelbase	in	mm	9.1	230	9.1	230	13.2	335	13.2	335
42	Service brake			Hydraulic Foot Pedal		Hydraulic Foot Pedal		Hydraulic Foot Pedal		Hydraulic Foot Pedal	
43	Parking brake			Mechanical Hand Lever		Mechanical Hand Lever		Mechanical Hand Lever		Mechanical Hand Lever	
POWERTRAIN											
44	Engine model			Isuzu 6BG1		Isuzu 6BG1		Isuzu 6BG1		Isuzu 6BG1	
45	Engine - continuous output S.A.E. gross	Hp	kW	114	83.8	114	83.8	117	86	117	86
46			at rpm	2000		2000		2100		2100	
47	Engine - maximum torque S.A.A. Gross	lb-ft	N-m	312	416.5	312	416.5	312	416.5	312	416.5
48			at rpm	1500		1500		1500		1500	
49	Number of cylinders			6		6		6		6	
50	Cylinder / displacement	cu in	L	396.3	6.494	396.3	6.494	396.3	6.494	396.3	6.494
51	Alternator output		amp	25		25		25		25	
52	Fuel tank capacity	US Gal	lit	37	140	37	140	37	140	37	140
53	Transmission - type			Automatic Power Shift		Automatic Power Shift		Automatic Power Shift		Automatic Power Shift	
54	Transmission - number of speeds forward / reverse			2 / 2		2 / 2		2 / 2		2 / 2	
55	Relief pressure for attachments	psi	MPa	2,844	200	2,844	200	2,844	200	2,844	200
56	Noise level - mean value at operator's ear Leq		dB(A)	85		85		85		85	

IC PNEUMATIC TIRE FORKLIFTS

FD60NH-FD100NH Series

6-10 ton capacity

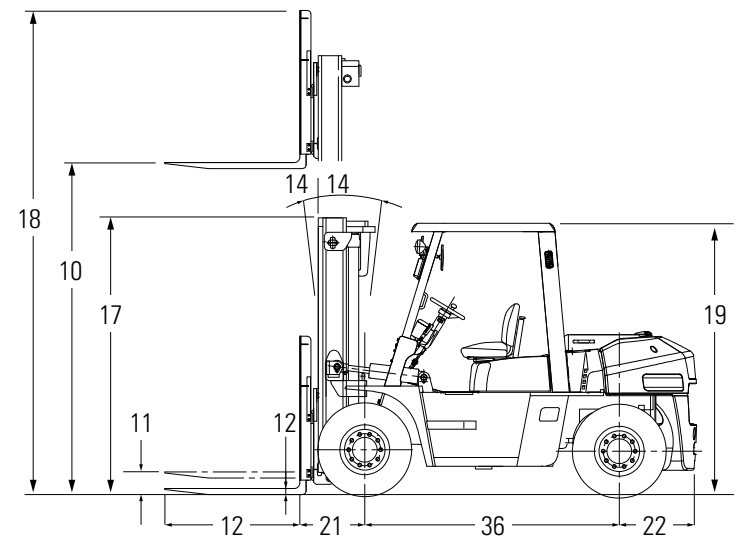
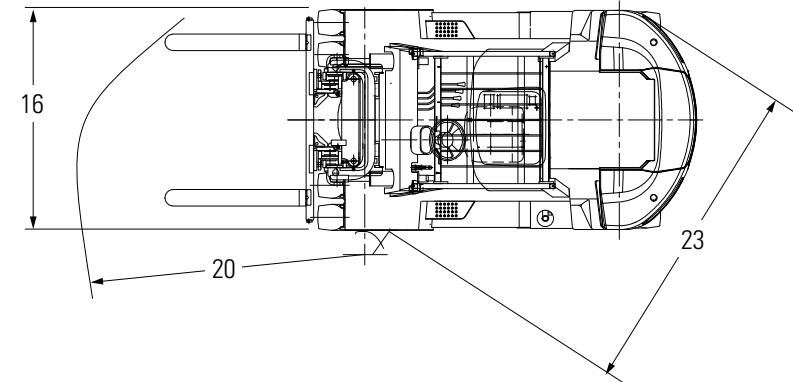

STANDARD EQUIPMENT & OPTIONS

FEATURES	STANDARD	OPTIONAL
Automatic shifting T/M	●	
Back-up Buzzer	●	
Back-up light	●	
Charging light	●	
Column shift direction change	●	
Convertor oil cooler	●	
Cyclopak air cleaner with dust indicator	●	
Documents clip	●	
Drawbar-pin	●	
Engine oil pressure warning light	●	
Fuel gauge	●	
Full wide carriage	●	
Glow plug indicator	●	
Head & turn signal lights	●	
Horn	●	
Hour meter	●	
Key switch engine stop	●	
Load backrest	●	
Load check valve	●	
Long life tires	●	
Neutral safety switch	●	
Overhead guard	●	
Power brake	●	
Power steering	●	
Radiator reserve tank	●	
Rear view mirrors	●	
Retaining rollers	●	
Starter switch	●	
Suspension seat	●	
Tilt adjustable handle	●	
Tool set	●	
Water temperature gauge	●	
Wide view mast	●	

IC PNEUMATIC TIRE FORKLIFTS

FD60NH-FD100NH Series

6-10 ton capacity



Small diameter steering wheel



One of the highest lift speeds in its class



Built to produce less noise for operator comfort



Audible and visual warnings, including a backup alarm, come standard



Dependable design providing a high level of safety



Electronic Controlled Automatic Transmission provides travel control with a single control lever

WHEN RELIABILITY IS EVERYTHING...



So when we promise you quality, reliability and value for money, you know it's a guarantee we have the power to deliver.

That's why every model in our awardwinning and comprehensive range of lift trucks and warehouse equipment is built to a high specification – to ensure it keeps working for you. Day after day. Year after year. Whatever the job. Whatever the conditions.

YOU'LL NEVER WORK ALONE

As your local authorized dealer, we are here to keep your trucks working – through our extensive experience, our technical excellence and our commitment to customer care.

We are your local experts, backed by efficient channels to the entire organization of Mitsubishi Forklift Trucks.

No matter where you are, we are close by – with the capability to meet your needs.

Performance specifications may vary depending on standard manufacturing tolerances, vehicle condition, types of tires, floor or surface conditions, applications or operating environment. Trucks may be shown with non-standard options. Specific performance requirements and locally available configurations should be discussed with your local dealer. We follow a policy of continual product improvement. For this reason, some materials, options and specifications could change without notice.