



# **PNEUMATIC TIRE FORKLIFT**

**13,000 - 22,000 LB CAPACITY DIESEL MODELS**

**THE HEAVY-DUTY FORKLIFT  
BUILT TO HANDLE TOUGH LOADS**



# PROVEN PERFORMANCE.

BUILT TO HANDLE HEAVY LOADS AND DELIVERS THE PERFORMANCE AND POWER REQUIRED BY TOUGH APPLICATIONS



- Exceptional power and performance
- Electronically controlled engine
- Durable steel frame for rugged applications
- Greater uptime and less maintenance

Extraordinary Performance, Exceptional Value: The FD60HP-FD100CP series delivers everything you need to power through tough jobs day after day – and at great value. From the dependable design to a high-performance engine, these lift trucks are ready to work when you are.

**Excellent Efficiency:** At the heart of the FD60HP-FD100CP series is the Kubota V3800 engine, one of the most robust, dependable and efficient diesel engines in its class. Even with producing low emissions, this electronically-controlled engine delivers maximum torque with low rpm. With a rugged transmission, triple hydraulics, wet disc brakes and an extra-large cooling system, this truck series delivers the productivity your business needs to keep moving.

**High Performance:** When you need power, you need it now. The new Kubota engine provides power while reducing fuel consumption. To create more power, the engines turbocharger compresses the inlet air forcing it into a chamber. Even at slower speeds, this constant pressure boost occurs over the entire rpm range for greater torque.

**Keeping Cool:** The reliable cooling system on the FD60HP-FD100CP trucks was designed to keep things cool even during heavy usage and high temperatures. To reduce flexing and helping to absorb vibrations, this cooling system includes a larger, heavy-duty, rubber mounted radiator.

**Key Applications:**

- Lumber
- Stone and glass
- Warehousing
- Manufacturing
- Recycling



Features	Standard	Optional
Two forward LED working lights	●	
Integrated Presence System	●	
Full-suspension seat	●	
Comfort seat		●

**Dependable Productivity**

Engine Protection System: These trucks feature an advanced engine protection system that automatically reduces engine speed in the event of overheating and keeps the truck running at desirable levels while helping to reduce the risk of damage to the forklift, saving you money. To help protect the machine's critical components, the large meter panel features a warning system that will alert the operator.

**Maintenance Made Simple:**

Simplified maintenance means less downtime. To cut maintenance time and costs, these trucks offer fast and easy access to key systems. Components that require regular maintenance or inspection can be accessed quickly and easily. The engine hood is equipped with gas-spring supports for easy open and closing.

- Greater uptime and lower planned maintenance costs
- Easy access to all major components
- Less time-consuming daily inspections

Ask your local dealer about the available options for improved performance, productivity and operator comfort.

# THE COMFORT YOUR OPERATORS DESERVE.

COMBINED WITH THE CONTROL YOUR BUSINESS DEMANDS.

Operator safety is key to business productivity. With excellent visibility and extraordinary reliability, the FD60HP-FD100CP series encourages a safe and highly productive workplace.

## Invaluable standard features:

- Spacious operator compartment
- Excellent visibility
- Ergonomically designed and logically-positioned controls

## Optimal Operator Compartment:

These trucks are built with the operator in mind. The wide carriage provides operators with exceptional forward and fork tip visibility and provides plenty



## Keeping Operators Alert:

This series of lift trucks are equipped with features to help keep operators alert and in control:

- Responsive hydrostatic steering
- Heavy insulation that reduces noise and engine heat
- Ergonomically and logically positioned controls
- Floating powertrain to reduce vibration
- Adjustable steering column

Operator Presence Systems: this safety system includes a seat-actuated power interrupt with mast-lock which automatically stops lifting and tilting change to functions if the operator is not in the seat. If the operator leaves the truck while it is still in gear, the system will automatically shift the transmission into neutral.

## LED Information Panel:

The easy-to-read meter panel provides constant status on crucial systems. The highly visible screen gives accurate readings of fuel and coolant levels, hour meter and any error codes.

- |                           |                                   |
|---------------------------|-----------------------------------|
| • Speedometer             | • Air cleaner                     |
| • Low engine oil pressure | • Rear tire steer angle indicator |
| • Check engine            | • Engine pre-heating glow plug    |
| • Battery charge          | • Engine coolant temperature      |
| • Check engine            | • Parking brake                   |
| • Seatbelt                |                                   |
| • Neutral transmission    |                                   |

## Smooth Rides:

To reduce operator fatigue, these trucks are equipped with a variety of features:

- Floating powertrain with independent dampeners
- Rubber shock absorbers located throughout the truck
- Standard thick, rubber, non-slip floor mat



CHARACTERISTICS			FD60P		FD60HP		FD70P		FD70HP		FD80P		FD100CP	
1	Capacity at rated load center	lb kg	13,000	6,000	13,000	6,000	15,500	7,000	15,500	7,000	17,500	8,000	22,000	8,000
2	Capacity at load center - Distance	in mm	24	600	24	600	24	600	24	600	24	600	24	600
3	Power - electric, diesel, gasoline or LP gas		Diesel		Diesel		Diesel		Diesel		Diesel		Diesel	
4	Tire type - cushion or pneumatic		Pneumatic		Pneumatic		Pneumatic		Pneumatic		Pneumatic		Pneumatic	
5	Wheels (x=driven) - number front / rear		4x / 2		4x / 2		4x / 2		4x / 2		4x / 2		4x / 2	
DIMENSIONS														
6	Maximum fork height (top of fork)	in mm	118	3,000	118	3,000	118	3,000	118	3,000	118	3,000	118	3,000
7	Free fork height	in mm	8.1	205	8.1	205	8.5	215	8.5	215	8.1	205	8.1	205
8	Forks - thickness x length x width	in mm	48.0 x 5.9 x 2.4	1,220 x 150 x 60	48.0 x 5.9 x 2.4	1,220 x 150 x 60	48.0 x 5.9 x 2.8	1,220 x 150 x 70	48.0 x 5.9 x 2.8	1,220 x 150 x 70	48.0 x 7.1 x 3.0	1,220 x 180 x 75	48.0 x 7.1 x 3.0	1,220 x 180 x 75
9	Fork spacing - out-to-out minimum / maximum	in mm	72.0 / 11.8	1,830 / 300	72.0 / 11.8	1,830 / 300	72.0 / 11.8	1,830 / 300	72.0 / 11.8	1,830 / 300	78.7 / 14.1	2,000 / 360	84.4 / 15.9	2,145 / 405
10	Tilt - forward / backward	deg	6 / 12		6 / 12		6 / 12		6 / 12		6 / 12		6 / 12	
11	Length to fork face	in mm	141.1	3,585	141.1	3,585	143.9	3,655	143.9	3,655	158.5	4,025	167.9	4,265
12	Width	in mm	78.9	2,005	78.9	2,005	78.9	2,005	78.9	2,005	85.6	2,175	88.4	2,245
13	Mast height fork lowered	in mm	98.4	2,500	98.4	2,500	98.4	2,500	98.4	2,500	110.2	2,800	112.2	2,850
14	Mast height fork raised	in mm	174	4,420	174	4,420	174	4,420	174	4,420	174	4,420	170.5	4,330
15	Height - to top of overhead guard	in mm	100.4	2,550	100.4	2,550	100.4	2,550	100.4	2,550	104.7	2,660	104.7	2,660
16	Height - with extended mast	in mm	252.7	6,420	252.7	6,420	252.7	6,420	252.7	6,420	252.7	6,420	249.2	6,330
17	Minimum outside turning radius	in mm	133.9	3,400	133.9	3,400	136.2	3,460	136.2	3,460	146.1	3,710	155.5	3,950
18	Rear overhang	in mm	26.4	670	26.4	670	28.7	730	28.7	730	31.7	805	29.5	750
19	Load distance (to fork face)	in mm	24.2	615	24.2	615	24.6	625	24.6	625	28.3	720	28.1	715
20	Minimum aisle - 90 degree stack - zero clearance without a load	in mm	206.7	5,250	206.7	5,250	210.6	5,350	210.3	5,350	222.4	5,650	232.3	5,900
PERFORMANCE														
21	Travel speed - loaded / empty	mph km/h	13 / 15.5	21 / 25	15.5 / 17.4	25 / 28	13 / 15.5	21 / 25	15.5 / 17.4	25 / 28	14.9 / 17.4	24 / 28	14.9 / 16.8	24 / 27
22	Lift speed - loaded / empty	fpm m/s	77.8 / 86.6	395 / 440	104.3 / 108.3	530 / 550	77.8 / 86.6	395 / 440	104.3 / 108.3	530 / 550	86.6 / 90.6	440 / 460	68.9 / 72.8	350 / 370
23	Lowering speed - loaded / empty	fpm m/s	88.6 / 98.4	450 / 500	88.6 / 98.4	450 / 500	88.6 / 98.4	450 / 500	88.6 / 98.4	450 / 500	88.6 / 88.6	450 / 450	88.6 / 68.9	450 / 350
24	Maximum drawbar pull - full / no load	lb N	11.0 / 4.9	49.0 / 21.6	12.3 / 4.9	54.9 / 21.6	11.0 / 4.9	49 / 21.6	12.3 / 4.9	54.9 / 21.6	13.5 / 6.2	59.8 / 27.5	14.3 / 7.1	63.7 / 31.4
25	Maximum gradeability - full load at 10mph	%	24		28		24		28		25		21	
26	Maximum gradeability - no load	%	20		20		20		20		20		20	
WEIGHT														
27	Empty	lbs kg	18,981.5	8,610	19,117	8,670	20,903	9,480	21,035	9,540	25,379	11,510	28,466	12,910
28	Axle load - with rated load front / rear	lbs kg	28,710 / 3,510	13,020 / 1,590	28,730 / 3,620	13,030 / 1,640	32,260 / 4,080	14,630 / 1,850	32,280 / 4,190	14,640 / 1,900	38,320 / 4,740	17,360 / 2,150	45,560 / 4,960	200
29	Axle load - without load front / rear	lbs kg	8,490 / 10,500	3,850 / 4,760	8,510 / 10,610	3,860 / 4,810	8,600 / 12,305	3,900 / 5,580	8,620 / 12,410	3,910 / 5,630	11,330 / 14,050	5,140 / 6,370	13,190 / 15,280	5,980 / 6,930
CHASSIS														
30	Tire Number - front / rear		4 / 2	4 / 2	4 / 2	4 / 2	4 / 2	4 / 2	4 / 2	4 / 2	4 / 2	4 / 2	4 / 2	4 / 2
31	Tire size - front, standard duals	in	8.25 - 15 - 14PR		8.25 - 15 - 14PR		8.25 - 15 - 14PR		8.25 - 15 - 14PR		9.00 - 20 - 14PR		9.00 - 20 - 14PR	
32	Tire size - rear tires	in	8.25 - 15 - 14PR		8.25 - 15 - 14PR		8.25 - 15 - 14PR		8.25 - 15 - 14PR		9.00 - 20 - 14PR		9.00 - 20 - 14PR	
33	Wheel base	in mm	90.6	2,300	90.6	2,300	90.6	2,300	90.6	2,300	98.4	2,500	98.4	2,800
34	Tread width - front, standard duals	in mm	57.9	1,470	57.9	1,470	57.9	1,470	57.9	1,470	63	1,600	63	1,600
35	Tread width - rear tires	in mm	66.9	1,700	66.9	1,700	66.9	1,700	66.9	1,700	66.9	1,700	66.9	1,700
36	Backrest height	in mm	53.9	1,370	53.9	1,370	53.5	1,360	53.5	1,360	53.3	1,355		
37	Overhead guard clearance	in mm	44.5	1,130	44.5	1,130	44.5	1,130	44.5	1,130	44.5	1,130	44.5	1,130
38	Drawbar pin center height	in mm	20.5	520	20.5	520	20.5	520	20.5	520	23.6	600	23.2	590
39	Floor Height	in mm	38.4	975	38.4	975	38.4	975	38.4	975	42.3	1,075	42.3	1,075
40	Ground clearance - at lowest point at mast	in mm	7.9	200	7.9	200	7.9	200	7.9	200	9.4	240	9.4	240
41	Ground clearance - at center of wheelbase	in mm	8.9	225	8.9	225	8.9	225	8.9	225	11.4	290	11.4	290
42	Service brake		Hydraulic foot pedal		Hydraulic foot pedal		Hydraulic foot pedal		Hydraulic foot pedal		Hydraulic foot pedal		Hydraulic foot pedal	
43	Parking brake		Mechanical hand lever		Mechanical hand lever		Mechanical hand lever		Mechanical hand lever		Mechanical hand lever		Mechanical hand lever	
POWERTRAIN														
44	Battery - voltage / capacity (5 hr)	V AH	12	70 x 2	12	70 x 2	12	70 x 2	12	70 x 2	12	70 x 2	12	70 x 2
45	Engine model		Kubota - V3800		Kubota - V3800		Kubota - V3800		Kubota - V3800		Kubota - V3800		Kubota - V3800	
46	Engine - continuous output S.A.E. gross	Hp kW	74	55	112	83	74	55	112	83	112	83	112	83
47		at rpm	2,200		2,200		2,200		2,200		2,200		2,200	
48	Engine - maximum torque S.A.A. gross	lb-ft N-m	229	310	284	385	229	310	284	385	284	385	284	385
49		at rpm	1,500		1,500		1,500		1,500		1,500		1,500	
50	Number of cylinders		4		4		4		4		4		4	
51	Cylinder / displacement	cu in L	230	3.769	230	3.769	230	3.796	230	3.796	230	3.796	230	3.796
52	Alternator output	amp	115		115		115		115		115		115	
53	Fuel tank capacity	Gal lit	39.6	150	39.6	150	39.6	150	39.6	150	39.6	150	39.6	150
54	Transmission - type		Automatic Power Shift		Automatic Power Shift		Automatic Power Shift		Automatic Power Shift		Automatic Power Shift		Automatic Power Shift	
55	Transmission - number of speeds forward/reverse		2 - 2		2 - 2		2 - 2		2 - 2		2 - 2		2 - 2	
56	Relief pressure for attachments	psi MPa	2,988	20.6	2,988	20.6	2,988	20.6	2,988	20.6	2,988	20.6	2,988	20.6
57	Noise level - mean value at operator's ear Leq	dB(A)	84		86		84		86		86		86	

Call-out numbers shown in the diagram below correspond to the first column of the specifications chart.

# FD60HP- FD100CP

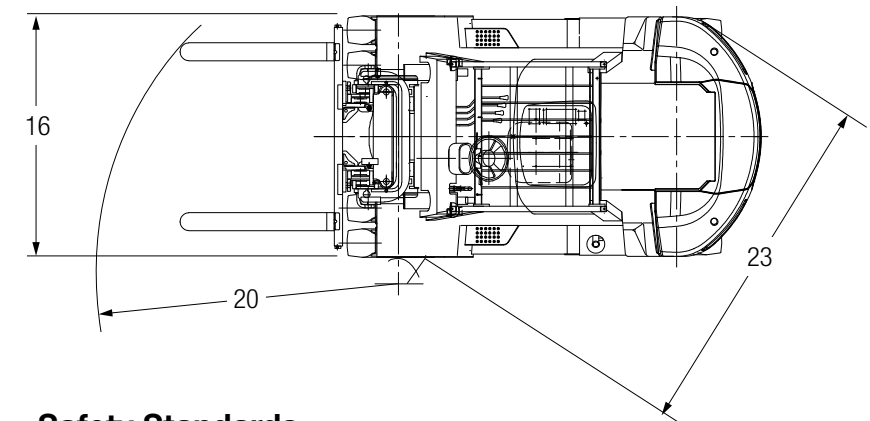
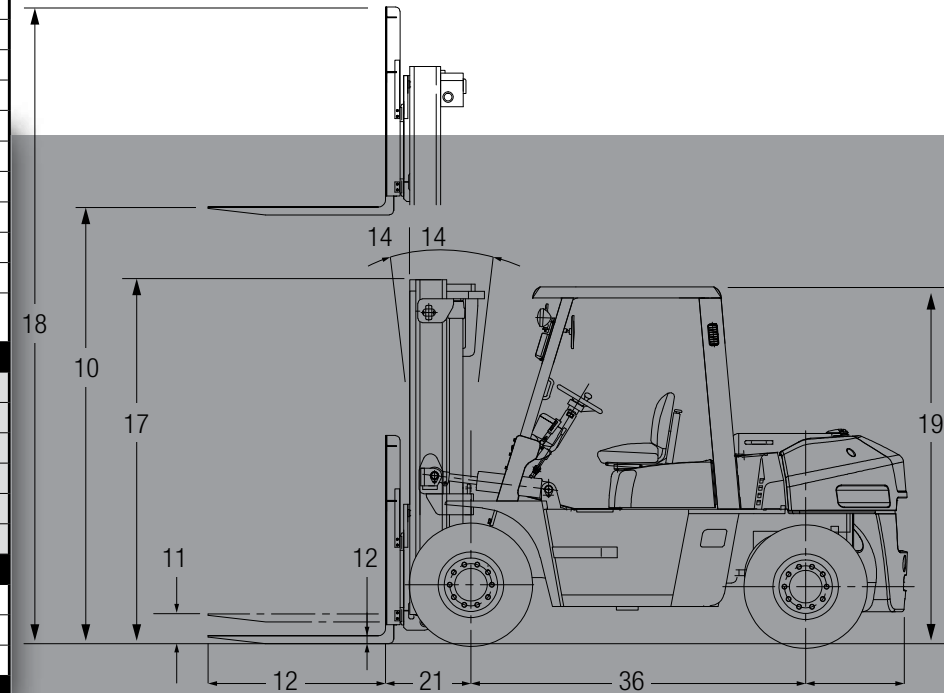

## Safety Standards

These trucks meet American National Standards Institute / Industrial Truck Standards Development Foundation, ANSI/ITSDF B56.1. Users should be aware of, and adhere to, applicable codes and regulations regarding operator training, use, operation and maintenance of powered industrial trucks, including:

- ANSI/ITSDF B56.1.
- NFPA 505, fire safety standard for powered industrial trucks – type designations, areas of use, maintenance, and operation.
- Occupational Safety and Health Administration (OSHA) regulations that may apply.

Specifications, equipment, technical data, photos and illustrations based on information at time of printing and subject to change without notice. Some products may be shown with optional equipment.

Contact your Mitsubishi forklift truck dealer for further information, including operator training programs and auxiliary visual and audible warning systems, fire extinguishers, etc., as available for specific user applications and requirements. Specifications, equipment, technical data, photos and illustrations based on information at time of printing and subject to change without notice. Some products may be shown with optional equipment.

# FD60HP-FD100CP

13,000-22,000 LB CAPACITY PNEUMATIC TIRE FORKLIFT

## Exceptional Value

### More Than 296,000 Parts To Keep You Running

Mitsubishi Forklift Trucks offers several parts programs, all designed to bring you top performance and convenience for your material handling needs. Contact your local dealer to put our services to work for you.

### Support To Fit Your Operation

Find out why more companies are relying on Mitsubishi forklift truck dealers to keep their fleet operating at top performance. Our efficiency provides customers with a better return on investment, and qualified service technicians, diverse parts inventory and unparalleled selection of service options can help reduce your total cost of ownership.

### Extensive Dealer Network

The Mitsubishi forklift truck dealer network is dedicated to finding the right forklift solution for your business. With more than 300 dealer locations, you can rely on your local dealer to provide the service you need when you need it most.



Manufactured with superior quality and exceptional value, Mitsubishi forklift trucks are supported by an extensive dealer and field support network located throughout North and South America. Don't forget to ask your local Mitsubishi forklift truck dealer about details on factory retail programs, financing plans and additional options and dealer services like planned maintenance and operator training.