



# PRODUCTIVITY, MAXIMIZED

**3,000 – 7,000 LB. CAPACITY  
INTERNAL COMBUSTION  
PNEUMATIC TIRE LIFT TRUCKS**



# PROVEN TO WORK HARDER



\*Based on cycle testing in which this model completed four more cycles per hour than the leading competitors. Assuming 10-hour shifts, five-day work weeks and a 52-week year, these results can be calculated to exceed 10,400 more cycles than the leading competition in a given year.

## Experience A New Level Of Productivity

Give your business a lift in productivity – by 10% with the Cat® 3,000 - 7,000 lb. IC pneumatic tire lift truck series. Proven to move 10,400 more loads per year than the leading competition\*, this series pushes through the hardest work days to help you move more – all day, every day.

### ADVANTAGES TO YOU:

- 3,000 – 7,000 lb. lift capacities
- Excellent travel speeds and powerful acceleration for greater productivity
- Superior lift and lower speeds result in lower cycle times
- Emission levels measure well below Environmental Protection Agency (EPA) Tier 4 final requirements
- World-class service and support provided by the best dealer network in the industry

### KEY APPLICATIONS:

- Building materials and garden supplies
- Chemicals and allied products
- Fabricated metal
- Industrial machinery and equipment
- Lumber and wood
- Primary metal
- Stone, clay and glass
- Wholesale trade durable goods

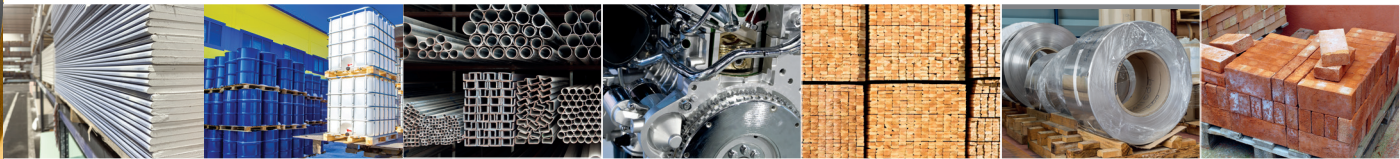

# HIGH PERFORMING, DURABLE AND



## To Keep Your Business Moving

The Cat pneumatic tire lift truck series  
is built to meet your business' every need.

### GREATER RELIABILITY, MAXIMUM UPTIME

- SmoothShift - Transmission Shift Inhibitor** – provides smooth direction shift changes, resulting in reduced Transmission shift shock, protecting the Drivetrain from full-speed shifts in direction, plus reduced tire spin, for increased tire life. This system helps reduce possible damage to the Driveline components due to the shock of high speed shifts, while also reducing tire spin to extend tire life. Option for LP/LPG models only.
- Cyclone Air Filter and High Position Air Intake** – the air intake system draws from higher levels where contamination is less likely, while the air filter reduces the risk of dirt entering the engine compartment and contaminating the engine oil. In addition to minimizing the risk of mechanical failure, this results in:
  - Reduced NOx emissions and particulate matter or soot
  - Lower fuel consumption
  - Increased power output
- Engine Protection System** – display-based indicators immediately notify the operator when vital fluids are low or engine maintenance is required, resulting in greater uptime while helping to prevent more costly maintenance.
- Durable Mast** – narrow flanges and 45° canted hoses and chains provide excellent visibility through the mast while the deep webs and six load rollers offer added strength and rigidity. Two contact points between the channels and the load rollers increase the mast's ability to handle side thrust forces while the side thrust rollers help maintain alignment.

# RELIABLE.



## DURABILITY

- **Swing Out LP Tank Bracket** – the standard bracket mounted to the counterweight helps create a secure position to remove and replace the LP tank. An assembly hinge is included to assist the operator in swinging out the LP tank bracket as well as returning it into a secure position.
- **Parking Brake / Transmission Interlock** – this standard feature helps protect brakes and transmissions from possible damage caused by driving with the parking brake engaged. Applications can reduce service costs incurred by premature brake wear or an overheated transmission. (For LP/LPG models only.)
- **Engine Shutdown System (optional)** – this system monitors the engine oil pressure and transmission and coolant temperatures. The lift truck will slow down or shut off the engine if the system recognizes pressure or temperature conditions that exceed preset levels.

## A STEP UP IN PRODUCTIVITY

This series reaches top speeds up to 7.5% faster on a 10% grade than the leading competition.

## MOVE 10,400 MORE LOADS

This Cat series delivers a 10% increase in productivity every shift.

# ENGINEERED FOR POWER AND PERFORMANCE



## **LP Max High Accuracy Fuel Level Sensor**

Providing a low LP fuel level warning to the operator an average of 8 minutes before the LP tank is empty, this system can improve plant productivity and reduce downtime. It can help save money on fuel by minimizing early tank replacement, while also reducing operation and labor costs associated with trucks running out of fuel and blocking aisles or operators walking back to the refill station.

## **Robust Powershift Transmission**

The Powershift transmission has a proven track record for quality and reliability that helps improve productivity by maximizing uptime.

Performance-matched with the dual fuel and diesel engines, it delivers rugged durability and fuel economy for optimum power and efficiency.

## **Durable Powerful Engines**

Built to excel in any application, tackle the toughest jobs and carry different attachments, Cat Lift Trucks offers several powerful engine options ranging from dual fuel to diesel with different horsepower/torque combinations to handle many applications.

These high efficiency engines meet or exceed EPA emissions regulations without the need for expensive after-treatment systems, minimizing cost and maintenance.



## DIESEL ENGINE – TIER 4 FINAL COMPLIANT

The 4EG 3.3L diesel engine is built with cutting-edge emissions technologies to meet the EPA's Tier 4 final requirements, while still maintaining the high levels of productivity that your business demands.

- **A high-pressure common rail fuel injection system** – ensures the diesel burns cleanly with optimum power output.
- **Exhaust gas recirculation system** – sends the exhaust gas back through the system after cooling to limit harmful emissions.

**After years of expertise and leadership in material handling solutions, Cat Lift Trucks engineered a game-changing powertrain for exceptional performance in the toughest material handling conditions.**

\*Fuel efficiency shown from preliminary testing, levels may vary depending on application.

# BIG ON COMFORT

## Designed For Optimum Control

The Cat GP15N/DP20N series is equipped with key features to help keep your operators alert and confident throughout the workday. Premium ergonomics and a smooth ride all come together to help your business achieve maximum productivity - all day, every day.

### INCREASED AWARENESS

- **Optimized Visibility** – narrow mast channels provide all-around visibility and clear sight lines to the surrounding job site, while the overhead guard and slim profile of the mast offer great visibility when driving and lifting.
- **Forward LED Work Lights** – mounted on the overhead guard, have a longer life, minimize glare and are cooler than traditional bulbs – all features that lower the cost of ownership while improving operator productivity.
- **Electronic Backup Alarm** – this series is equipped with an audible backup alarm. The alarm sounds anytime the truck is in reverse, alerting pedestrians and other operators working nearby.
- **Seatbelt Interlock Options** – function to restrict truck operation if the seatbelt is not latched. These options can help improve operator confidence, plus promote compliance with OSHA seatbelt requirements and an application's operational rules. For LP/LPG models only.



### GROUND SPEED CONTROL

Software and sensors limit the maximum travel speed of the truck without limiting its performance. See your local Cat lift truck dealer for flexibility in adjusting the speed in applications requiring stricter policies. Multiple speed control options available in addition to ground speed control for LP/LPG models.

### PRESENCE DETECTION SYSTEM (PDS)

The Presence Detection System (PDS) activates whenever the operator leaves the normal operating position. This integral computer-based feedback system uses both audible and visual indicators to alert the operator to potentially hazardous situations, while increasing operator awareness.

- When the operator is not in the normal operating position, the PDS electronically discontinues powered-travel movement and load-handling functions.

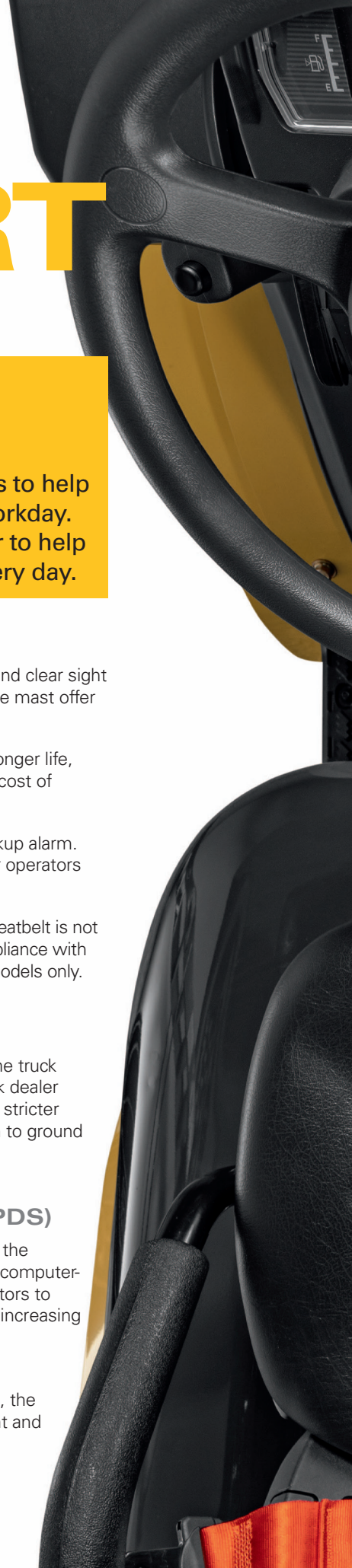

**Premium LED/LCD Display**  
Monitors all critical systems to reduce risk of downtime and help minimize costs

**Dual Action Parking Brake**  
Helps minimize the chance of the operator accidentally releasing the brake

**Hydraulic Power Steering**  
Enhances operator control and maneuverability

**Tilt Steering Column With Mechanical Quick Return**  
Memory function returns the column and locks it to a pre-set position

**Electronic Direction Control**  
Allows easier direction changes for smooth acceleration

**Separate Brake And Inching Pedals**  
For greater operator control

**Optional Fingertip Controls**  
Enables precise load control with easy movement and excellent hand positioning

**Full-Suspension Seat With Orange Anti-Cinch Seat Belt**  
Adjustable suspension, lumbar support and seat angle

**Maintain Comfort While Maximizing Performance**  
Premium ergonomics and control features come together for maximum productivity and ease of use.

**WARNING** IMPROPER OPERATION OR MAINTENANCE COULD RESULT IN INJURY OR DEATH

MODEL:	MAX. POSE HEIGHT:	MAX. WEIGHT:	
SERIAL No:			
ATTACH 1:			
ATTACH 2:			
TRUCK WEIGHT	A-LOAD CENTER	B-OFFSET	CAPACITY
kg	mm	in	kg
lbs	in	in	lbs

MEETS DESIGN SPECIFICATIONS OF ANSI/ITSDF B56.1

CAPACITY SPECIFIED FOR THE TRUCK REQUIRES TIRES AUTHORIZED BY THE MANUFACTURER



Local service and support



Genuine OEM parts



Custom financing packages

# MORE CONFIDENCE





Factory warranty for added protection



## Local Support You Can Count On

A Cat lift truck purchase connects you to a variety of material handling solutions, including world-class service and support from your local, trusted dealer. With trained service technicians, a diverse parts inventory and a broad selection of service options, your local dealer can help you lower costs, enhance productivity and more efficiently manage your business.

### FINANCING MADE SIMPLE

Financing your next Cat lift truck is easy with our wide range of flexible leasing and purchasing options. Whether you want to finance or lease, your local Cat lift truck dealer can help customize a package for your business.

### WHEN EVERY PART COUNTS

When buying from your local Cat lift truck dealer, you can rest assured that your genuine OEM parts are manufactured to meet original equipment criteria. Additionally, all Cat lift trucks OEM parts come with a six-month, unlimited-hours warranty.

When speed is critical, our Parts Fast Or Parts Free Guarantee\* ensures next-business-day delivery of all Cat lift trucks parts, or they're free, including freight. If your part doesn't come in by the next business day, we pay for it.

### STANDING BEHIND OUR PRODUCTS

We deliver peace of mind by helping your lift trucks stay on the job. Every new Cat lift truck is covered by a 1-year / 2,000-hours warranty that includes parts and labor, as well as components and systems. With our standard 2-year / 4,000-hours extended powertrain warranty, you'll have the confidence that only comes from owning a Cat lift truck.

\* At dealer's location.

† Programs may be subject to change without notice and may vary by region. Please ask your local Cat lift truck dealer for complete terms and conditions.

## Specifications

Characteristics				GP15N		GP18N		GP20CN		
1	Capacity at rated load center	lb	kg	3,000	1,500	3,500	1,750	4,000	2,000	1
2	Capacity at load center – distance	in	mm	24	500	24	500	24	500	2
3	Power – electric, diesel, dual fuel: gasoline/LP gas			dual fuel: gasoline/LP gas		dual fuel: gasoline/LP gas		dual fuel: gasoline/LP gas		3
4	Tire type – cushion or pneumatic			pneumatic		pneumatic		pneumatic		4
5	Wheels (x=driven) – number front / rear			2x / 2		2x / 2		2x / 2		5
Dimensions				GP15N		GP18N		GP20CN		
6	Maximum fork height (top of fork) <sup>1)</sup>	in	mm	131	3,325	131	3,325	131	3,325	6
7	Free fork height <sup>1)</sup>	in	mm	4.5	115	4.5	115	4.7	120	7
8	Forks – thickness x length x width <sup>1)</sup>	in	mm	1.4x42.0x3.9	35x 1,070x 100	1.4x42.0x3.9	35x 1,070x 100	1.6x42.0x3.9	40x 1,070x 100	8
9	Fork spacing – out-to-out minimum / maximum	in	mm	7.9 / 36.2	200 / 920	7.9 / 36.2	200 / 920	7.9 / 36.2	200 / 920	9
10	Tilt – forward / backward	deg		6° / 10°		6° / 10°		6° / 10°		10
11	Length to fork face	in	mm	89.0	2,260	90.4	2,295	92.5	2,350	11
12	Width – with single drive tires	in	mm	41.9	1,065	41.9	1,065	41.9	1,065	12
13	Width – with dual drive tires			-	-	-	-	-	-	13
14	Height – with lowered mast <sup>1)</sup>	in	mm	84.5	2,140	84.5	2,140	84.5	2,140	14
15	Seat height to SIP	in	mm	44.4	1,127	44.4	1,127	44.4	1,127	15
16	Height – to top of overhead guard	in	mm	82.7	2,100	82.7	2,100	82.7	2,100	16
17	Height – with extended mast <sup>1)</sup>	in	mm	179	4,549	179	4,549	179	4,549	17
18	Minimum outside turning radius	in	mm	76.8	1,950	78.0	1,980	79.5	2,020	18
19	Load moment constant	in	mm	15.7	400	15.7	400	16.3	415	19
20	Minimum aisle – 90° stack – zero clearance without a load	in	mm	92.5	2,350	93.7	2,380	95.9	2,435	20
Performance				GP15N		GP18N		GP20CN		
21	Travel speed – loaded / empty	mph	km/h	10.9 / 11.8	17.5 / 19.0	10.9 / 11.8	17.5 / 19.0	11.2 / 11.5	18.0 / 18.5	21
22	Lift speed – loaded / empty	fpm	m/s	122 / 124	0.62 / 0.63	122 / 124	0.62 / 0.63	122 / 124	0.62 / 0.63	22
23	Lowering speed – loaded / empty	fpm	m/s	98.4 / 98.4	0.50 / 0.50	98.4 / 98.4	0.50 / 0.50	98.4 / 98.4	0.50 / 0.50	23
24	Drawbar pull – loaded at 1 mph (1.6 km)	lb	N	3,910	17,400	3,910	17,400	3,870	17,200	24
25	Drawbar pull – loaded maximum	lb	N	4,560	20,300	4,560	20,300	4,500	20,000	25
26	Gradeability – loaded at 1 mph (1.6 km)	%		39.0		39.0		38.0		26
27	Gradeability – maximum loaded	%		63.0		55.0		46.0		27
Weight				GP15N		GP18N		GP20CN		
28	Empty	lb	kg	5,650	2,560	6,070	2,750	6,750	3,040	28
29	Axle load – with rated load front / rear	lb	kg	7,710 / 940	3,620 / 440	8,460 / 1,110	3,980 / 520	9,370 / 1,380	4,390 / 650	29
30	Axle load – without load front / rear	lb	kg	2,490 / 3,160	1,130 / 1,430	2,370 / 3,700	1,080 / 1,670	2,390 / 4,360	1,080 / 1,960	30
Chassis				GP15N		GP18N		GP20CN		
31	Tire size – front, standard	in		6.5 x 10 - 10PR		6.5 x 10 - 10PR		6.5 x 10 / 5.0 Solid		31
32	Tire size – optional duals	in		-		-		-		32
33	Tire size – rear tires	in		5.0 x 8 - 10PR		5.0 x 8 - 10PR		5.0 x 8 / 3.0 Solid		33
34	Wheelbase	in	mm	55.1	1,400	55.1	1,400	55.1	1,400	34
35	Tread width – front (standard / optional duals)	in	mm	35.0 / -	890 / -	35.0 / -	890 / -	35.0 / -	890 / -	35
36	Tread width – rear tires	in	mm	35.4	900	35.4	900	35.4	900	36
37	Ground clearance – at lowest point at mast	in	mm	4.3	110	4.3	110	4.3	110	37
38	Ground clearance – at center of wheelbase	in	mm	6.0	152	6.0	152	6.0	152	38
39	Service brake			foot-operated, hydraulic		foot-operated, hydraulic		foot-operated, hydraulic		39
40	Parking brake			hand, mechanical		hand, mechanical		hand, mechanical		40
Powertrain				GP15N		GP18N		GP20CN		
41	Engine model			EK21E		EK21E		EK21E		41
42	Engine – continuous output S.A.E. gross	HP	kW	53.0	40	53.0	40	53.0	40	42
43		at rpm		2,700		2,700		2,700		43
44	Engine – maximum torque S.A.E. gross	lb-ft	N-m	110	153	110	153	110	153	44
45		at rpm		1,800		1,800		1,800		45
46	Cylinder / displacement	cu in	L	4 / 126	4 / 2.1	4 / 126	4 / 2.1	4 / 126	4 / 2.1	46
47	Transmission – type			powershift		powershift		powershift		47
48	Transmission – number of speeds forward / reverse			1 / 1		1 / 1		1 / 1		48
49	Battery	volts		12		12		12		49
50	Relief pressure for attachments	psi	bar	2,610	180	2,610	180	2,610	180	50
51	Noise level – mean value at operator's ear Leq	dB(A)		73.5		73.5		73.5		51

1) Heights with listed forks on standard two-stage mast. Optional forks will change dimensions slightly.

DISCLAIMER: The information in these materials is being provided for marketing and informational purposes only. Actual specifications, functions, and performance may vary from those set forth in these materials and are available upon request. Operators should always consult the applicable Logisnext Operator's Manual and/or Service Manuals prior to use. Nothing in these materials is intended to constitute a representation, warranty or guarantee for any equipment sold and Logisnext hereby disclaims the same.

GP20N		GP25N		GP28N		GP30N		GP33N		GP35N		
1	4,000	2,000	5,000	2,500	5,500	2,800	6,000	3,000	6,500	3,300	7,000	3,500
2	24	500	24	500	24	500	24	500	24	500	24	500
3	dual fuel: gasoline/LP gas		dual fuel: gasoline/LP gas		dual fuel: gasoline/LP gas		dual fuel: gasoline/LP gas		dual fuel: gasoline/LP gas		dual fuel: gasoline/LP gas	
4	pneumatic		pneumatic		pneumatic		pneumatic		pneumatic		pneumatic	
5	2x / 2		2x / 2		2x / 2		2x / 2		2x / 2		2x / 2	
GP20N		GP25N		GP28N		GP30N		GP33N		GP35N		
6	131.5	3,340	131.5	3,340	130.5	3,315	130.5	3,315	131.5	3,350	131.5	3,350
7	5.5	140	5.5	140	5.7	145	5.7	145	5.9	150	5.9	150
8	1.6x42.0x3.9	40x 1,070x 100	1.6x42.0x3.9	40x 1,070x 100	1.8x42.0x4.9	45x 1,070x 125	1.8x42.0x4.9	45x 1,070x 125	2.0x42.0x4.9	50x 1,070x 125	2.0x42.0x4.9	50x 1,070x 125
9	8.7 / 39.4	220 / 1,000	8.7 / 39.4	220 / 1,000	9.8 / 39.4	250 / 1,000	9.8 / 39.4	250 / 1,000	9.8 / 39.4	250 / 1,000	9.8 / 39.4	250 / 1,000
10	6° / 10°		6° / 10°		6° / 10°		6° / 10°		6° / 10°		6° / 10°	
11	98.0	2,490	100	2,550	104	2,645	107	2,720	108	2,750	110	2,790
12	45.3	1,150	45.3	1,150	50.2	1,275	50.2	1,275	50.2	1,275	50.8	1,290
13	64.6	1,640	64.6	1,640	67.5	1,715	67.5	1,715	67.5	1,715	67.5	1,715
14	84.5	2,145	84.5	2,145	85.5	2,165	85.5	2,165	90.5	2,299	90.5	2,299
15	44.8	1,137	44.8	1,137	46.7	1,187	46.7	1,187	46.7	1,187	46.7	1,187
16	82.9	2,105	82.9	2,105	83.7	2,125	83.7	2,125	83.7	2,125	84.3	2,140
17	180	4,564	180	4,564	178.5	4,536	178.5	4,536	180	4,566	180	4,566
18	86.6	2,200	87.8	2,230	91.1	2,315	93.7	2,380	95.7	2,430	96.1	2,440
19	17.9	455	17.9	455	19.3	490	19.3	490	19.3	490	19.5	495
20	105	2,655	106	2,685	110	2,805	113	2,870	115	2,920	116	2,935
GP20N		GP25N		GP28N		GP30N		GP33N		GP35N		
21	10.6 / 11.5	170 / 18.5	10.6 / 11.5	170 / 18.5	10.6 / 11.2	170 / 18.0	10.6 / 11.2	170 / 18.0	10.9 / 11.5	175 / 18.5	10.9 / 11.5	175 / 18.5
22	124 / 128	0.63 / 0.65	124 / 128	0.63 / 0.65	98.4 / 102	0.50 / 0.52	98.4 / 102	0.50 / 0.52	98.4 / 102	0.50 / 0.52	82.7 / 86.6	0.42 / 0.44
23	98.4 / 98.4	0.50 / 0.50	98.4 / 98.4	0.50 / 0.50	98.4 / 98.4	0.50 / 0.50	98.4 / 98.4	0.50 / 0.50	98.4 / 98.4	0.50 / 0.50	98.4 / 98.4	0.50 / 0.50
24	4,920	21,900	4,900	21,800	4,990	22,200	4,990	22,200	4,610	20,500	4,610	20,500
25	5,640	25,100	5,670	25,200	5,800	25,800	5,800	25,800	5,310	23,600	5,310	23,600
26	39.0		40.0		36.0		34.0		29.0		27.0	
27	570		49.0		43.0		41.0		33.0		32.0	
GP20N		GP25N		GP28N		GP30N		GP33N		GP35N		
28	7,370	3,340	7,990	3,620	9,090	4,120	9,400	4,260	10,150	4,600	10,340	4,690
29	9,950 / 1,420	4,660 / 685	11,570 / 1,420	5,450 / 670	12,950 / 1,640	6,100 / 70	13,790 / 1,610	6,390 / 870	14,590 / 2,060	6,880 / 970	15,400 / 1,990	7,250 / 940
30	3,240 / 4,130	1,470 / 1,870	3,190 / 4,800	1,440 / 2,180	3,670 / 5,420	1,660 / 2,460	3,860 / 5,540	1,700 / 2,560	3,790 / 6,360	1,710 / 2,890	3,700 / 6,640	1,680 / 3,010
GP20N		GP25N		GP28N		GP30N		GP33N		GP35N		
31	70 x 12 - 12PR		70 x 12 - 12PR		28 x 9 x 15 - 12PR		28 x 9 x 15 - 12PR		250 x 15 - 16PR		250 x 15 - 16PR	
32	70 x 12 - 12PR		70 x 12 - 12PR		28 x 9 x 15 - 12PR		28 x 9 x 15 - 12PR		28 x 9 x 15 - 12PR		28 x 9 x 15 - 12PR	
33	6.0 x 9 - 10PR		6.0 x 9 - 10PR		6.5 x 10 - 10PR		6.5 x 10 - 10PR		6.5 x 10 - 12PR		6.5 x 10 - 12PR	
34	63.0	1,600	63.0	1,600	63.8	1,620	66.9	1,700	66.9	1,700	66.9	1,700
35	37.8 / 47.4	960 / 1,205	37.8 / 47.4	960 / 1,205	41.7 / 47.2	1,060 / 1,200	41.7 / 47.2	1,060 / 1,200	41.7 / 47.2	1,060 / 1,200	41.7 / 47.2	1,060 / 1,200
36	38.6	980	38.6	980	38.6	980	38.6	980	38.6	980	38.6	980
37	4.6	117	4.6	117	5.4	136	5.4	136	5.4	136	5.7	146
38	6.6	167	6.6	167	7.4	189	7.4	189	7.4	189	8.0	202
39	foot-operated, hydraulic		foot-operated, hydraulic		foot-operated, hydraulic		foot-operated, hydraulic		foot-operated, hydraulic		foot-operated, hydraulic	
40	hand, mechanical		hand, mechanical		hand, mechanical		hand, mechanical		hand, mechanical		hand, mechanical	
GP20N		GP25N		GP28N		GP30N		GP33N		GP35N		
41	EK25E		EK25E		EK25E		EK25E		EK25E		EK25E	
42	61.0	44	61.0	44	61.0	44	61.0	44	61.0	44	61.0	44
43	2,700		2,700		2,700		2,700		2,700		2,700	
44	129	168	129	168	129	168	129	168	129	168	129	168
45	1,600		1,600		1,600		1,600		1,600		1,600	
46	4 / 152	4 / 2.5	4 / 152	4 / 2.5	4 / 152	4 / 2.5	4 / 152	4 / 2.5	4 / 152	4 / 2.5	4 / 152	4 / 2.5
47	powershift		powershift		powershift		powershift		powershift		powershift	
48	1 / 1		1 / 1		1 / 1		1 / 1		1 / 1		1 / 1	
49	12		12		12		12		12		12	
50	2,610	180	2,610	180	2,610	180	2,610	180	2,610	180	2,610	180
51	76.5		76.5		76.5		76.5		76.5		76.5	

**NOTE:** These specifications assume the use of drive axles, tires and tilt angles specified. Any modification to specifications, or any other combination of specifications made after the shipment of the truck, requires prior written approval from Logisnext Americas Inc. (See ANSI/ITSDF B56.1.) Also be advised that overall operating visibility may be affected by the mast configuration and mast options of your truck. Therefore, you may need to add ancillary [auxiliary] devices or modify your operating practices. Consult your dealer for further information.

## Specifications

Characteristics				DP20N		DP25N		DP28N	
1	Capacity at rated load center	lb	kg	4,000	2,000	5,000	2,500	5,500	2,800
2	Capacity at load center – distance	in	mm	24	500	24	500	24	500
3	Power – electric, diesel, dual fuel: gasoline/LP gas			diesel		diesel		diesel	
4	Tire type – cushion or pneumatic			pneumatic		pneumatic		pneumatic	
5	Wheels (x=driven) – number front / rear			2x / 2		2x / 2		2x / 2	
Dimensions				DP20N		DP25N		DP28N	
6	Maximum fork height (top of fork) <sup>1)</sup>	in	mm	131.5	3,340	131.5	3,340	130.5	3,315
7	Free fork height <sup>1)</sup>	in	mm	5.5	140	5.5	140	5.7	145
8	Forks – thickness x length x width <sup>1)</sup>	in	mm	1.6x42.0x3.9	40x 1,070x 100	1.6x42.0x3.9	40x 1,070x 100	1.8x42.0x4.9	45x 1,070x 125
9	Fork spacing – out-to-out minimum / maximum	in	mm	8.7 / 39.4	2220 / 1,000	8.7 / 39.4	220 / 1,000	9.8 / 39.4	250 / 1,000
10	Tilt – forward / backward		deg	6° / 10°		6° / 10°		6° / 10°	
11	Length to fork face	in	mm	98.0	2,490	100	2,550	104	2,645
12	Width – with single drive tires	in	mm	45.3	1,150	45.3	1,150	50.2	1,275
13	Width – with dual drive tires			64.6	1,640	64.6	1,640	67.5	1,715
14	Height – with lowered mast <sup>1)</sup>	in	mm	84.5	2,145	84.5	2,145	85.5	2,165
15	Seat height to SIP	in	mm	44.8	1,137	44.8	1,137	46.7	1,187
16	Height – to top of overhead guard	in	mm	82.9	2,105	82.9	2,105	83.7	2,125
17	Height – with extended mast <sup>1)</sup>	in	mm	180	4,564	180	4,564	178.5	4,536
18	Minimum outside turning radius	in	mm	86.6	2,200	87.8	2,230	91.1	2,315
19	Load moment constant	in	mm	17.9	455	17.9	455	19.3	490
20	Minimum aisle – 90° stack – zero clearance without a load	in	mm	105	2,655	106	2,685	110	2,805
Performance				DP20N		DP25N		DP28N	
21	Travel speed – loaded / empty	mph	km/h	10.3 / 11.2	16.5 / 18.0	10.3 / 10.9	16.5 / 17.5	9.9 / 10.9	16.0 / 17.5
22	Lift speed – loaded / empty	fpm	m/s	120 / 126	0.61 / 0.64	120 / 126	0.61 / 0.64	96.5 / 100	0.49 / 0.51
23	Lowering speed – loaded / empty	fpm	m/s	98.4 / 98.4	0.50 / 0.50	98.4 / 98.4	0.50 / 0.50	98.4 / 98.4	0.50 / 0.50
24	Drawbar pull – loaded at 1 mph (1.6 km)	lb	N	3,960	17,600	3,960	17,600	3,960	17,600
25	Drawbar pull – loaded maximum	lb	N	4,520	20,100	4,520	20,100	4,540	20,200
26	Gradeability – loaded at 1 mph (1.6 km)		%	36.0		31.0		28.0	
27	Gradeability – maximum loaded		%	42.0		37.0		32.0	
Weight				DP20N		DP25N		DP28N	
28	Empty	lb	kg	7,540	3,420	8,210	3,720	9,330	4,230
29	Axle load – with rated load front / rear	lb	kg	10,340 / 1,610	4,690 / 730	11,650 / 1,560	5,490 / 730	13,050 / 1,780	6,150 / 830
30	Axle load – without load front / rear	lb	kg	3,310 / 4,230	1,500 / 1,920	3,260 / 4,950	1,480 / 2,240	3,730 / 5,600	1,690 / 2,540
Chassis				DP20N		DP25N		DP28N	
31	Tire size – front, standard	in		70 x 12 - 12PR		70 x 12 - 12PR		28 x 9 x 15 - 12PR	
32	Tire size – optional duals	in		70 x 12 - 12PR		70 x 12 - 12PR		28 x 9 x 15 - 12PR	
33	Tire size – rear tires	in		6.0 x 9 - 10PR		6.0 x 9 - 10PR		6.5 x 10 - 10PR	
34	Wheelbase	in	mm	63.0	1,600	63.0	1,600	63.8	1,620
35	Tread width – front (standard / optional duals)	in	mm	37.8 / 47.4	960 / 1,205	37.8 / 47.4	960 / 1,205	41.7 / 47.2	1,060 / 1,200
36	Tread width – rear tires	in	mm	38.6	980	38.6	980	38.6	980
37	Ground clearance – at lowest point at mast	in	mm	4.6	117	4.6	117	5.4	136
38	Ground clearance – at center of wheelbase	in	mm	6.6	167	6.6	167	7.4	189
39	Service brake			foot-operated, hydraulic		foot-operated, hydraulic		foot-operated, hydraulic	
40	Parking brake			hand, mechanical		hand, mechanical		hand, mechanical	
Powertrain				DP20N		DP25N		DP28N	
41	Engine model			4EG		4EG		4EG	
42	Engine – continuous output S.A.E. gross	HP	kW	48.0	36.0	48.0	36.0	48.0	36.0
43		at rpm		2,250		2,250		2,250	
44	Engine – maximum torque S.A.E. gross	lb-ft	N-m	131	177	131	177	131	177
45		at rpm		1,800		1,800		1,800	
46	Cylinder / displacement	cu in	L	4 / 203	4 / 3.3	4 / 203	4 / 3.3	4 / 203	4 / 3.3
47	Transmission – type			powershift		powershift		powershift	
48	Transmission – number of speeds forward / reverse			1 / 1		1 / 1		1 / 1	
49	Battery		volts	12		12		12	
50	Relief pressure for attachments	psi	bar	2,610	180	2,610	180	2,610	180
51	Noise level – mean value at operator's ear Leq		dB(A)	75.5		75.5		75.5	

1) Heights with listed forks on standard two-stage mast. Optional forks will change dimensions slightly.

**NOTE:** These specifications assume the use of drive axles, tires and tilt angles specified. Any modification to specifications, or any other combination of specifications made after the shipment of the truck, requires prior written approval from Logisnext Americas Inc. (See ANSI/ITSDF B56.1.) Also be advised that overall operating visibility may be affected by the mast configuration and mast options of your truck. Therefore, you may need to add ancillary (auxiliary) devices or modify your operating practices. Consult your dealer for further information.

Call-out numbers shown in the diagram correspond to the first column of the specifications chart.

	DP30N		DP33N		DP35N	
1	6,000	3,000	6,500	3,300	7,000	3,500
2	24	500	24	500	24	500
3	diesel		diesel		diesel	
4	pneumatic		pneumatic		pneumatic	
5	2x / 2		2x / 2		2x / 2	
	DP30N		DP33N		DP35N	
6	130.5	3,315	131.5	3,350	131.5	3,350
7	5.7	145	5.9	150	5.9	150
8	1.8x42.0x4.9	45x 1,070x 125	2.0x42.0x4.9	50x 1,070x 125	2.0x42.0x4.9	50x 1,070x 125
9	9.8 / 39.4	250 / 1,000	9.8 / 39.4	250 / 1,000	9.8 / 39.4	250 / 1,000
10	6° / 10°		6° / 10°		6° / 10°	
11	107	2,720	108	2,750	110	2,790
12	50.2	1,275	50.2	1,275	50.8	1,290
13	67.5	1,715	67.5	1,715	67.5	1,715
14	85.5	2,165	90.5	2,299	90.5	2,299
15	46.7	1,187	46.7	1,187	46.7	1,187
16	83.7	2,125	83.7	2,125	84.3	2,140
17	178.5	4,536	180	4,566	180	4,566
18	93.7	2,380	95.7	2,430	96.1	2,440
19	19.3	490	19.3	490	19.5	495
20	113	2,870	115	2,920	116	2,935
	DP30N		DP33N		DP35N	
21	9.9 / 10.9	16.0 / 17.5	10.3 / 11.2	16.5 / 18.0	10.3 / 11.2	16.5 / 18.0
22	96.5 / 100	0.49 / 0.51	96.5 / 100	0.49 / 0.51	80.7 / 84.6	0.41 / 0.43
23	98.4 / 98.4	0.50 / 0.50	98.4 / 98.4	0.50 / 0.50	98.4 / 98.4	0.50 / 0.50
24	3,960	17,600	3,620	16,100	3,620	16,100
25	4,540	20,200	4,140	18,400	4,140	18,400
26	26.0		22.0		21.0	
27	30.0		25.0		24.0	
	DP30N		DP33N		DP35N	
28	9,640	4,370	10,390	4,710	10,590	4,800
29	13,890 / 1,750	6,550 / 820	14,700 / 2,190	6,920 / 1,040	15,500 / 2,130	7,300 / 1,000
30	3,920 / 5,720	1,770 / 2,600	3,890 / 6,500	1,760 / 2,950	3,820 / 6,770	1,730 / 3,070
	DP30N		DP33N		DP35N	
31	28 x 9 x 15 - 12PR		250 x 15 - 16PR		250 x 15 - 16PR	
32	28 x 9 x 15 - 12PR		28 x 9 x 15 - 12PR		28 x 9 x 15 - 12PR	
33	6.5 x 10 - 10PR		6.5 x 10 - 12PR		6.5 x 10 - 12PR	
34	66.9	1,700	66.9	1,700	66.9	1,700
35	41.7 / 47.2	1,060 / 1,200	41.7 / 47.2	1,060 / 1,200	41.7 / 47.2	1,060 / 1,200
36	38.6	980	38.6	980	38.6	980
37	5.4	136	5.4	136	5.7	146
38	7.4	189	7.4	189	8.0	202
39	foot-operated, hydraulic		foot-operated, hydraulic		foot-operated, hydraulic	
40	hand, mechanical		hand, mechanical		hand, mechanical	
	DP30N		DP33N		DP35N	
41	4EG		4EG		4EG	
42	48.0	36.0	48.0	36.0	48.0	36.0
43	2,250		2,250		2,250	
44	131	177	131	177	131	177
45	1,800		1,800		1,800	
46	4 / 203	4 / 3.3	4 / 203	4 / 3.3	4 / 203	4 / 3.3
47	powershift		powershift		powershift	
48	1 / 1		1 / 1		1 / 1	
49	12		12		12	
50	2,610	180	2,610	180	2,610	180
51	75.5		75.5		75.5	

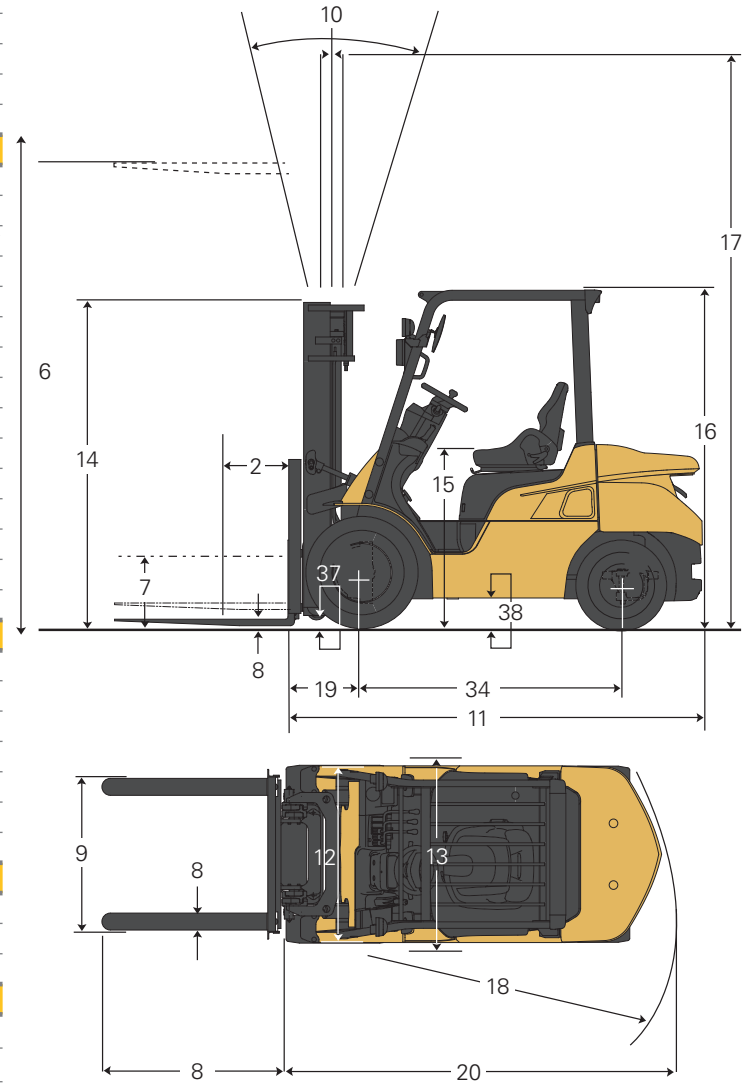

### Safety Standards

These trucks meet American National Standards Institute/Industrial Truck Standards Development Foundation, ANSI/ITSDF B56.1.

UL-Classified by Underwriters Laboratories, Inc., as to fire and electric shock hazard only. Availability: Types G/LP and D standard. Types GS/LPS and DS Option (subject to availability). Users should be aware of, and adhere to, applicable codes and regulations regarding operator training, use, operation, and maintenance of powered industrial trucks, including:

- ANSI/ITSDF B56.1.
- NFPA 505, fire safety standard for powered industrial trucks — type designations, areas of use, maintenance and operation.
- Occupational Safety and Health Administration (OSHA) regulations that may apply.

Contact your Cat lift truck dealer for further information, including operator training programs and auxiliary visual and audible warning systems, fire extinguishers, etc., as available for specific user applications and requirements. Specifications, equipment, technical data, photos and illustrations based on information at time of printing and subject to change without notice. Some products may be shown with optional equipment.



**Your Cat lift truck dealer** can provide additional options and features to specialize your lift truck for your unique application. Operator training and custom financing programs are also available to help find the right fit for your business.

Helping move businesses forward – that’s how we’re built.

**1-800-CAT-LIFT | [www.logisnextamericas.com/cat](http://www.logisnextamericas.com/cat)**

© 2026 Logisnext Americas Inc. CAT, CATERPILLAR, LET’S DO THE WORK, their respective logos, “Caterpillar Corporate Yellow”, the “Power Edge”, and Cat “Modern Hex” trade dress as well as corporate and product identity used herein, are trademarks of Caterpillar used under license and may not be used without permission from Caterpillar.

Some products may be shown with optional equipment.

CECV0400

03/26

