



BUILT FOR POWER

**13,000 - 22,000 LB. CAPACITY
INTERNAL COMBUSTION
PNEUMATIC TIRE LIFT TRUCK**



DESIGNED FOR SUCCESS.

Class-leading Performance

The Cat® DP60HP-DP100CP series is built for some of the most challenging environments as well as lifting and hauling heavy loads with amazing speed and productivity. It also delivers a low cost of ownership while offering low emissions. This forklift is not only reliable and tough, but also has incredible operator comfort to fit all of your needs.

ADVANTAGES TO YOU:

- Controlled, yet powerful acceleration maximizes productivity.
- World-class service and support provided by the best dealer network in the industry.
- Includes one of the most powerful, durable and efficient diesels in its class.
- Excellent visibility and exceptional reliability help you create a safe and highly productive workplace.

POWER

This truck has a class-leading four-cylinder common rail turbo diesel EPA Tier 4 engine that produces exceptionally high power at all times, even in hard-wearing applications, and comes with a low maintenance DOC/SCR System.

PERFORMANCE

Equipped with intelligent systems and intuitive hydraulics, this lift truck series offers high productivity for your business - day in and day out. The Advanced Selective Catalytic Reduction system converts harmful gasses into harmless nitrogen and water, allowing the truck to emit low exhaust emissions levels.

SAFETY & COMFORT

The robust cabin design is reinforced to minimize stress points during heavy lifting, and includes equipment ergonomically designed to allow for strain-free operation with minimal movement required from the operator.

DURABILITY

Designed to work in rugged conditions, these trucks power through tough jobs. The design allows for easy maintenance and very high efficiency, reducing downtime and costs for repairs and worn part replacements.





KEY APPLICATIONS:

- Lumberyards
- Brickyards
- Warehousing
- Recycling
- Manufacturing







Strength and Power You Can Count On

Designed to deliver maximum uptime no matter the challenge, this truck provides a high level of servicing ease and greater protection to critical components for reliability you can depend on and profit from.

FEATURES:

- Five-piece overhead guard takes 75% less time to make needed replacements versus competitive designs using a single-piece, welded-on guard. That cuts downtime and costs.
- Heavy duty clear-view mast provides excellent visibility and contributes to faster cycle times.
- Components that require regular changing or inspection can be accessed quickly and easily. The engine hood has gas-spring supports to open and close easily.
- The front and rear floorboards can be removed and reinstalled without any tools for access to the transmission and hydraulics.
- Features simplified design with fewer service points for quicker, simpler maintenance.
- The advanced Engine Protection System automatically reduces engine speed in the event of overheating. The large meter panel features a warning system that alerts the operator to help protect the machine's critical components.
- Includes a Kubota V3800 engine, one of the most powerful, durable and efficient diesels in its class. This turbocharged, electronically-controlled engine pours out massive torque at low rpm — producing very low emissions.
- Features a switch that changes the speed pattern of the transmission, allowing your operator to select the best mode for the current working conditions. This enhances both operating efficiency and fuel economy.
- Wet Disc Brakes help ensure stops and lessen operator fatigue.



GREAT OPERATOR SUPPORT



COMFORTABLE RIDE

- **Spacious and comfortable operator compartment**
Suitable for a wide range of operator sizes, the ergonomic layout helps to reduce fatigue throughout long shifts, increasing productivity.
- **Travel controls**
With a small diameter steering wheel to help reduce operator fatigue.
- **Forward visibility**
Wide carriage provides excellent forward and fork tip visibility for greater security and productivity.



ER



POWER AND SAFETY

- **The low pedal angles** allow for easy movement between the gas and brake pedals. This truck includes a full hydraulic powered brake system for safe stops and less operator fatigue. The powered brakes also provide emergency braking power in the event the engine is stopped.
- **The operator presence system** includes a seat-actuated power interrupt with mast-lock, automatically preventing lift and tilt operations if the operator leaves the seat.

ADVANCED DESIGN FEATURES

Features a floating powertrain that includes independent dampeners to reduce vibrations that can cause operator fatigue. Vibration is further reduced by rubber shock absorbers located throughout the truck and a standard thick, rubber, non-slip floor mat.

GREATER COMFORT AND SUPPORT

Operators can maneuver with greater confidence from the full-suspension seat. The seat reclines and adjusts easily to match its operator's weight. This truck also includes side supports and fore-and-aft positioning for additional comfort.



Local service and support



Genuine OEM parts



Custom financing packages

MORE CONFIDENCE





Factory warranty for added protection



Local Support You Can Count On

A Cat lift truck purchase connects you to a variety of material handling solutions, including world-class service and support from your local, trusted dealer. With trained service technicians, a diverse parts inventory and a broad selection of service options, your local dealer can help you lower costs, enhance productivity and more efficiently manage your business.

FINANCING MADE SIMPLE

Financing your next Cat lift truck is easy with our wide range of flexible leasing and purchasing options. Whether you want to finance or lease, your local Cat lift truck dealer can help customize a package for your business.

WHEN EVERY PART COUNTS

When buying from your local Cat lift truck dealer, you can rest assured that your genuine OEM parts are manufactured to meet original equipment criteria. Additionally, all Cat lift trucks OEM parts come with a six-month, unlimited-hours warranty.

When speed is critical, our Parts Fast Or Parts Free Guarantee* ensures next-business-day delivery of all Cat lift trucks parts, or they're free, including freight. If your part doesn't come in by the next business day, we pay for it.

STANDING BEHIND OUR PRODUCTS

We deliver peace of mind by helping your lift trucks stay on the job. Every new Cat lift truck is covered by a 1-year / 2,000-hours warranty that includes parts and labor, as well as components and systems. With our standard 2-year / 4,000-hours extended powertrain warranty, you'll have the confidence that only comes from owning a Cat lift truck.

* At dealer's location.

† Programs may be subject to change without notice and may vary by region. Please ask your local Cat lift truck dealer for complete terms and conditions.

10 Specifications

Characteristics				DP60P		DP60HP		DP70P		DP70HP	
1	Capacity at rated load center	lb	kg	13,000	6,000	13,000	6,000	15,500	7,000	15,500	7,000
2	Capacity at load center - Distance	in	mm	24	600	24	600	24	600	24	600
3	Power - electric, diesel, gasoline or LP gas			Diesel		Diesel		Diesel		Diesel	
4	Tire type - cushion or pneumatic			Pneumatic		Pneumatic		Pneumatic		Pneumatic	
5	Wheels (x=driven) - number front / rear			4x / 2		4x / 2		4x / 2		4x / 2	
Dimensions				DP60P		DP60HP		DP70P		DP70HP	
6	Maximum fork height (top of fork)	in	mm	118	3,000	118	3,000	118	3,000	118	3,000
7	Free fork height	in	mm	8.1	205	8.1	205	8.5	215	8.5	215
8	Forks - thickness x length x width	in	mm	48.0x5.9x2.4	1,220x150x60	48.0x5.9x2.4	1,220x150x60	48.0x5.9x2.8	1,220x150x70	48.0x5.9x2.8	1,220x150x70
9	Fork spacing - out-to-out minimum / maximum	in	mm	72.0 / 11.8	1,830 / 300	72.0 / 11.8	1,830 / 300	72.0 / 11.8	1,830 / 300	72.0 / 11.8	1,830 / 300
10	Tilt - forward / backward	deg		6 / 12		6 / 12		6 / 12		6 / 12	
11	Length to fork face	in	mm	141.1	3,585	141.1	3,585	143.9	3,655	143.9	3,655
12	Width	in	mm	78.9	2,005	78.9	2,005	78.9	2,005	78.9	2,005
13	Mast height fork lowered	in	mm	98.4	2,500	98.4	2,500	98.4	2,500	98.4	2,500
14	Mast height fork raised	in	mm	174	4,420	174	4,420	174	4,420	174	4,420
15	Height - to top of overhead guard	in	mm	100.4	2,550	100.4	2,550	100.4	2,550	100.4	2,550
16	Height with extended mast at VM500	in	mm	252.7	6,420	252.7	6,420	252.7	6,420	252.7	6,420
17	Minimum outside turning radius	in	mm	133.9	3,400	133.9	3,400	136.2	3,460	136.2	3,460
18	Rear overhang	in	mm	26.4	670	26.4	670	28.7	730	28.7	730
19	Load distance (to front fork face)	in	mm	24.2	615	24.2	615	24.6	625	24.6	625
20	Minimum aisle - 90° stack - zero clearance w/o load	in	mm	206.7	5,250	206.7	5,250	210.6	5,350	210.3	5,350
Performance				DP60P		DP60HP		DP70P		DP70HP	
21	Travel speed - loaded / empty	mph	km/h	13 / 15.5	21 / 25	15.5 / 17.4	25 / 28	13 / 15.5	21 / 25	15.5 / 17.4	25 / 28
22	Lift speed - loaded / empty	fpm	m/s	77.8 / 86.6	395 / 440	104.3 / 108.3	530 / 550	77.8 / 86.6	395 / 440	104.3 / 108.3	530 / 550
23	Lowering speed - loaded / empty	fpm	m/s	88.6 / 98.4	450 / 500	88.6 / 98.4	450 / 500	88.6 / 98.4	450 / 500	88.6 / 98.4	450 / 500
24	Maximum drawbar pull - full / no load	lb	N	11.0 / 4.9	49.0 / 21.6	12.3 / 4.9	54.9 / 21.6	11.0 / 4.9	49 / 21.6	12.3 / 4.9	54.9 / 21.6
25	Maximum gradeability - full load at 10mph	%		24		28		24		28	
26	Maximum gradeability - no load	%		20		20		20		20	
Weight				DP60P		DP60HP		DP70P		DP70HP	
27	Empty	lbs	kg	18,981.5	8,610	19,114	8,670	20,903	9,480	21,035	9,540
28	Axle load - with rated load front / rear	lbs	kg	28,710 / 3,510	13,020 / 1,590	28,730 / 3,620	13,030 / 1,640	32,260 / 4,080	14,630 / 1,850	32,280 / 4,190	14,640 / 1,900
29	Axle load - without load front / rear	lbs	kg	8,490 / 10,500	3,850 / 4,760	8,510 / 10,610	3,860 / 4,810	8,600 / 12,305	3,900 / 5,580	8,620 / 12,410	3,910 / 5,630
Chassis				DP60P		DP60HP		DP70P		DP70HP	
30	Tire Number - front / rear			4 / 2	4 / 2	4 / 2	4 / 2	4 / 2	4 / 2	4 / 2	4 / 2
31	Tire size - front, standard duals	in		8.25 - 15 - 14PR		8.25 - 15 - 14PR		8.25 - 15 - 14PR		8.25 - 15 - 14PR	
32	Tire size - rear tires	in		8.25 - 15 - 14PR		8.25 - 15 - 14PR		8.25 - 15 - 14PR		8.25 - 15 - 14PR	
33	Wheel base	in	mm	90.6	2,300	90.6	2,300	90.6	2,300	90.6	2,300
34	Tread width - front, standard duals	in	mm	57.9	1,470	57.9	1,470	57.9	1,470	57.9	1,470
35	Tread width - rear tires	in	mm	66.9	1,700	66.9	1,700	66.9	1,700	66.9	1,700
36	Backrest height	in	mm	53.9	1,370	53.9	1,370	53.5	1,360	53.5	1,360
37	Overhead guard clearance	in	mm	44.5	1,130	44.5	1,130	44.5	1,130	44.5	1,130
38	Drawbar pin center height	in	mm	20.5	520	20.5	520	20.5	520	20.5	520
39	Floor Height	in	mm	38.4	975	38.4	975	38.4	975	38.4	975
40	Ground clearance - at lowest point at mast	in	mm	7.9	200	7.9	200	7.9	200	7.9	200
41	Ground clearance - at center of wheelbase	in	mm	8.9	225	8.9	225	8.9	225	8.9	225
42	Service brake			Hydraulic foot pedal		Hydraulic foot pedal		Hydraulic foot pedal		Hydraulic foot pedal	
43	Parking brake			Mechanical hand lever		Mechanical hand lever		Mechanical hand lever		Mechanical hand lever	
Powertrain				DP60P		DP60HP		DP70P		DP70HP	
44	Battery - voltage / capacity (5 hr)	V	AH	12	70 x 2	12	70 x 2	12	70 x 2	12	70 x 2
45	Engine model			Kubota - V3800		Kubota - V3800		Kubota - V3800		Kubota - V3800	
46	Engine - continuous output S.A.E. gross	Hp	kW	74	55	112	83	74	55	112	83
47		at rpm		2,200		2,200		2,200		2,200	
48	Engine - maximum torque S.A.A. Gross	lb-ft	N-m	229	310	284	385	229	310	284	385
49		at rpm		1,500		1,500		1,500		1,500	
50	Number of cylinders			4		4		4		4	
51	Cylinder / displacement	cu in	L	230	3.769	230	3.769	230	3.796	230	3.796
52	Alternator output	amp		115		115		115		115	
53	Fuel tank capacity	Gal	lit	39.6	150	39.6	150	39.6	150	39.6	150
54	Transmission - type			Automatic Power Shift		Automatic Power Shift		Automatic Power Shift		Automatic Power Shift	
55	Transmission - number of speeds forward / reverse			2 - 2		2 - 2		2 - 2		2 - 2	
56	Relief pressure for attachments	psi	MPa	2,988	20.6	2,988	20.6	2,988	20.6	2,988	20.6
57	Noise level - mean value at operator's ear Leq	dB(A)		84		86		84		86	

1) Heights with shaft type forks on standard two-stage mast. Optional hook type forks will change dimensions slightly.

DP60HP-DP100CP

DP80P			DP100CP			
1	lb	kg	17,500	8,000	22,000	10,000
2	in	mm	24	600	24	600
3			Diesel		Diesel	
4			Pneumatic		Pneumatic	
5			4x / 2		4x / 2	
DP80P			DP100CP			
6	in	mm	118	3,000	118	3,000
7	in	mm	8.1	205	8.1	205
8	in	mm	48.0x7.1x3.0	1,220x180x75	48.0x7.1x3.0	1,220x180x75
9	in	mm	78.7 / 14.1	2,000 / 360	84.4 / 15.9	2,145 / 405
10	deg		6 / 12		6 / 12	
11	in	mm	158.5	4,025	167.9	4,265
12	in	mm	85.6	2,175	88.4	2,245
13	in	mm	110.2	2,800	112.2	2,850
14	in	mm	174	4,420	170.5	4,330
15	in	mm	104.7	2,660	104.7	2,660
16	in	mm	252.7	6,420	249.2	6,330
17	in	mm	146.1	3,710	155.5	3,950
18	in	mm	31.7	805	29.5	750
19	in	mm	28.3	720	28.1	715
20	in	mm	222.4	5,650	232.3	5,900
DP80P			DP100CP			
21	mph	km/h	14.9 / 17.4	24 / 28	14.9 / 16.8	24 / 27
22	fpm	m/s	86.6 / 90.6	440 / 460	68.9 / 72.8	350 / 370
23	fpm	m/s	88.6 / 88.6	450 / 450	88.6 / 68.9	450 / 350
24	lb	N	13.5 / 6.2	59.8 / 275	14.3 / 7.1	63.7 / 31.4
25	%		25		21	
26	%		20		20	
DP80P			DP100CP			
27	lbs	kg	25,379	11,510	28,466	12,910
28	lbs	kg	38,280 / 4,740	17,360 / 2,150	45,560 / 4,960	20,660 / 2,250
29	lbs	kg	11,330 / 14,050	5,140 / 6,370	13,190 / 15,280	5,980 / 6,930
DP80P			DP100CP			
30			4 / 2	4 / 2	4 / 2	4 / 2
31	in		9.00 - 20 - 14PR		9.00 - 20 - 14PR	
32	in		9.00 - 20 - 14PR		9.00 - 20 - 14PR	
33	in	mm	98.4	2,500	98.4	2,800
34	in	mm	63	1,600	63	1,600
35	in	mm	66.9	1,700	66.9	1,700
36	in	mm	53.3	1,355	Without Backrest	
37	in	mm	44.5	1,130	44.5	1,130
38	in	mm	23.6	600	23.2	590
39	in	mm	42.3	1,075	42.3	1,075
40	in	mm	9.4	240	9.4	240
41	in	mm	11.4	290	11.4	290
42			Hydraulic foot pedal		Hydraulic foot pedal	
43			Mechanical hand lever		Mechanical hand lever	
DP80P			DP100CP			
44	V	AH	12	70 x 2	12	70 x 2
45			Kubota - V3800		Kubota - V3800	
46	Hp	kW	112	83	112	83
47	at rpm		2,200		2,200	
48	lb-ft	N-m	284	385	284	385
49	at rpm		1,500		1,500	
50			4		4	
51	cu in	L	230	3.796	230	3.796
52	amp		115		115	
53	Gal	lit	39.6	150	39.6	150
54			Automatic Power Shift		Automatic Power Shift	
55			2 - 2		2 - 2	
56	psi	MPa	2,988	20.6	2,988	20.6
57		dB(A)	86		86	

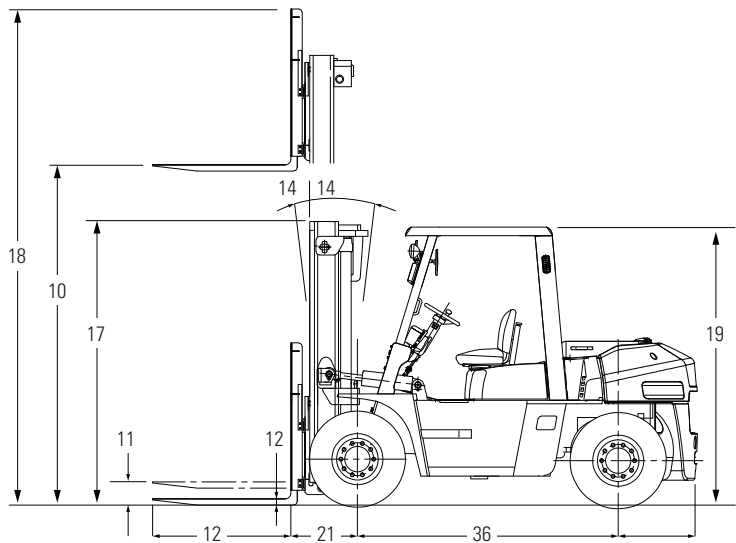
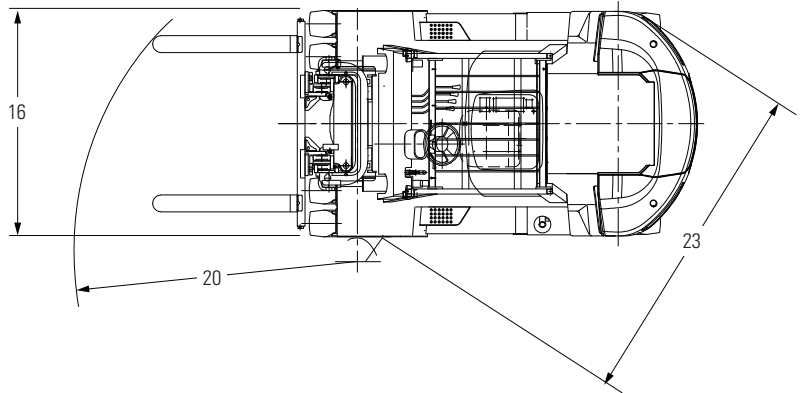

Safety Standards

These trucks meet American National Standards Institute/ Industrial Truck Standards Development Foundation, ANSI/ITSDF B56.1. Users should be aware of, and adhere to, applicable codes and regulations regarding operator training, use, operation and maintenance of powered industrial trucks, including:

- ANSI/ITSDF B56.1.
- NFPA 505, fire safety standard for powered industrial trucks – type designations, areas of use, maintenance and operation.
- Occupational Safety and Health Administration (OSHA) regulations that may apply.

Specifications, equipment, technical data, photos and illustrations based on information at time of printing and subject to change without notice. Some products may be shown with optional equipment.



Your Cat lift truck dealer can provide additional options and features to specialize your lift truck for your unique application. Operator training and custom financing programs are also available to help find the right fit for your business.

Helping move businesses forward – that's how we're built.

1-800-CAT-LIFT | www.logisnextamericas.com/cat

© 2026 Logisnext Americas Inc. CAT, CATERPILLAR, LET'S DO THE WORK, their respective logos, "Caterpillar Corporate Yellow," the "Power Edge" and Cat "Modern Hex" trade dress as well as corporate and product identity used herein, are trademarks of Caterpillar used under license and may not be used without permission from Caterpillar.

Some products may be shown with optional equipment.

CECV0404

04/26

