



MAXIMUM EFFICIENCY

3,000 – 4,000 LB. CAPACITY
ELECTRIC STAND-UP COUNTERBALANCE

CAT[®]

LONG-LASTING POWER, EXCEPTIONAL FLEXIBILITY.

Delivering Maximum Performance

Combining the latest in operator ergonomics and advanced AC control, the Cat® ECS14N-ECS18N series of electric stand-up counterbalanced lift trucks provides maximum power and performance in a variety of applications.

ADVANTAGES TO YOU:

- Convenient battery and extraction access options.
- Low energy consumption – runs up to two shifts on one battery charge.*
- Sealed systems, including IP54-rated motors, provide added protection against dust, moisture and other debris to take on tough applications.

KEY INDUSTRIES:

- Food Production & Distribution
- Retail Distribution
- General Manufacturing



INCREASED PRODUCTIVITY

The advanced AC motor provides high torque for greater productivity.

LITHIUM-ION AVAILABILITY:

- Greater power efficiency
- Run for 24 hours a day, 7 days a week with opportunity charging
- Zero battery maintenance
- No watering
- No more battery exchanges
- No gas emissions, odor or acidification
- No special charging areas or equipment needed
- Longer lasting life cycles (up to 3,000)
- 5-year warranty on batteries
- 2-year warranty on chargers

* in most applications.



FIRST CLASS. PERFORMANCE. FROM THE INSIDE, OUT.



ENERGY EFFICIENT, 3-PHASE AC TECHNOLOGY

The innovative three-phase AC motors in these lift trucks are engineered for maximum efficiency and performance. Through advanced regenerative braking, the motors are designed to act as a generator during braking, effectively turning the truck's momentum into energy and feeding it back into the battery. This, combined with the truck's intelligent design and compact component layout, result in:

- **Longer run times**
Up to two shifts on one battery charge in most applications.
- **Greater torque**
Even at low speeds, with no torque gaps or speed loss
- **High throughput efficiency**
Even when changing travel directions

LESS MAINTENANCE, EASY TO SERVICE

With extended service intervals and sealed components, these lift trucks provide greater uptime to keep your business moving, while having an overall lower cost of ownership.

- **1,000-hour service intervals**
- **Valuable display-based maintenance reminders**
- **Easy access to service components**
 - Easy to remove covers – with no tools required
 - Fewer parts, with less to service

RELIABLE MOTORS

- **Closed electric motors** allow these lift trucks to operate in many environments.
- **Fully-enclosed motor** with fewer parts means less maintenance. The motor's compact design and proximity to other related system components provides increased energy efficiency, helping you get more out of each shift
- **Ingress protected** sealed systems provide added protection against dust, moisture and other debris to take on your toughest application.
 - IP54 rated motors
 - IP65 rated connectors

DYNAMIC PERFORMANCE

Advanced AC technology also ensures responsive acceleration and braking, allowing for:

- **Precise positioning**
- **Dynamic acceleration**
- **Controlled travel speed on ramps**
- **Less brake component wear and lower maintenance costs**



Increased Productivity, Less Maintenance

The ECS14N – ECS18N series of stand-up counterbalanced lift trucks is designed to maximize uptime. From low maintenance components to high-efficiency systems, these lift trucks will get the job done.

EXPERIENCE COMFORT AND CONTROL.

A Productive Shift From Beginning To End.

Operators can get their work done comfortably with the innovative ergonomic design.

A CONTROL ROOM DESIGNED AROUND THE OPERATOR

Intuitive Multifunction Control Handle

- The centrally positioned handle allows the operator to drive, lift, lower and use auxiliary hydraulic functions – all at the same time.
- Electric power steering translates to precise steering control with minimal effort.
- Dual pedal design for added security.



Electronically-Adjustable Armrest and Backrest

This unique feature will fit most operator sizes, providing excellent comfort – adjustable up to 4 inches vertically.



Generous Cushioning

270° cushioning surrounds the operator's knee, back and waist, helping to ensure a continuous, comfortable-ride experience.

Excellent Operator Awareness

- Vibrant 4-inch, full-color display provides all vital information at a glance.
- The precisely-engineered overhead guard offers optimized visibility while stacking and is still compatible in drive-in racking applications.



ECHO Control Handle Option

The ECHO handle is not considered an upgrade to the standard ergonomic handle, but allows operators familiar with this style of side grip control to easily operate these trucks.





WORK HARD. WORK SAFE.

INTELLIGENT TECHNOLOGY YOU CAN COUNT ON.

- **Customizable Tilt Speeds** at all heights prevent damage to the load or drop down.
- **Ramp Hold**, allows the operator to effectively stop and prevent roll-back while operating on ramps and inclines.
- **Three pre-programmed performance modes** allows you to customize individual drive and hydraulic settings based on the application or operator experience level, either through the display or through a laptop or handheld device.

TRUCK BASICS

- **Horn Operations Controlled With Lever**
- **Emergency Power Disconnect**
- **Electronic Parking Brake**
- **2 LED Front Work Lights**
- **Optional Light Packages**



* Ask your local dealer about additional safety accessories and options.

GET THE WORK DONE, YOUR WAY.

A wide-variety of application packages to meet your needs.

COLD STORAGE APPLICATION

- Designed for freezer applications, where the truck goes into and out of the freezer for short periods of time.
- Ideal for applications where the ambient temperature fluctuates between 20 degrees and 70 degrees Fahrenheit.

FREEZER APPLICATION

- Applications where the ambient temperature fluctuates between minus 40 degrees and 40 degrees Fahrenheit.
- Applications where the truck operates continuously between minus 40 degrees and minus 20 degrees Fahrenheit.

DRIVE-IN RACK APPLICATION

- An optional 50" chassis frame is available for more narrow drive-in rack applications.
- 83" and 91" overhead guard options are also available.





Local service and support



Genuine OEM parts



Custom financing packages

MORE CONFIDENCE





Factory warranty for added protection



Local Support You Can Count On

A Cat lift truck purchase connects you to a variety of material handling solutions, including world-class service and support from your local, trusted dealer. With trained service technicians, a diverse parts inventory and a broad selection of service options, your local dealer can help you lower costs, enhance productivity and more efficiently manage your business.

FINANCING MADE SIMPLE

Financing your next Cat lift truck is easy with our wide range of flexible leasing and purchasing options. Whether you want to finance or lease, your local Cat lift truck dealer can help customize a package for your business.

WHEN EVERY PART COUNTS

When buying from your local Cat lift truck dealer, you can rest assured that your genuine OEM parts are manufactured to meet original equipment criteria. Additionally, all Cat lift trucks OEM parts come with a six-month, unlimited-hours warranty.

STANDING BEHIND OUR PRODUCTS

We deliver peace of mind by helping your lift trucks stay on the job. Every new Cat lift truck is covered by a 1-year / 2,000-hours warranty that includes parts and labor, as well as components and systems. With our standard 2-year / 4,000-hours extended powertrain warranty, you'll have the confidence that only comes from owning a Cat lift truck.

* At dealer's location.

† Programs may be subject to change without notice and may vary by region.
Please ask your local Cat lift truck dealer for complete terms and conditions.

Specifications

| Characteristics | | | | ECS14N | | ECS16N | | ECS18N | | |
|-----------------|---|-----|------|---|----------------------|---------------|----------------------|---------------|----------------------|--|
| 1 | Capacity at rated load center | lb | kg | 3,000 | 1,364 | 3,500 | 1,591 | 4,000 | 1,818 | |
| 2 | Capacity load center - distance from fork face | in | mm | 24 | 600 | 24 | 600 | 24 | 600 | |
| 3 | Power voltage | V | | | 36 AC electric | | 36 AC electric | | 36 AC electric | |
| 4 | Tire type, drive / steer | | | | solid rubber / poly | | solid rubber / poly | | solid rubber / poly | |
| 5 | Wheels (x=driven) | | | | 2x / 2 | | 2x / 2 | | 2x / 2 | |
| Dimensions | | | | ECS14N | | ECS16N | | ECS18N | | |
| 6 | Maximum fork height lift with standard triplex mast | in | mm | 188 | 4,775 | 188 | 4,775 | 188 | 4,775 | |
| 7 | Free fork height lift with standard triplex mast | in | mm | 35 | 889 | 35 | 889 | 35 | 889 | |
| 8 | Fork width | in | mm | 3.9 | 100 | 3.9 | 100 | 3.9 | 100 | |
| 9 | Fork thickness | in | mm | 1.4 | 35 | 1.4 | 35 | 1.6 | 40 | |
| 10 | Fork spacing – out-to-out minimum | in | mm | 9.5 | 240 | 9.5 | 240 | 9.5 | 240 | |
| 11 | Fork spacing – out-to-out maximum | in | mm | 36.5 | 920 | 36.5 | 920 | 36.5 | 920 | |
| 12 | Tilt angle, forward / backward | deg | | 3 / 5 | | 3 / 5 | | 3 / 5 | | |
| 13 | Mast width | in | mm | 22 | 570 | 22 | 570 | 22 | 570 | |
| 14 | Length to fork face | in | mm | 63.0 | 1,601 | 65.0 | 1,652 | 70.0 | 1,778 | |
| 15 | Overall chassis width | in | mm | 41 | 1,041 | 41 | 1,041 | 41.0 | 1,041 | |
| 16 | Overall lowered height (mast) | in | mm | 82.9 | 2,105 | 82.9 | 2,105 | 82.9 | 2,105 | |
| 17 | Overall lowered height to top of overhead guard | in | mm | 88.0 | 2,240 | 88.0 | 2,240 | 88.0 | 2,240 | |
| 18 | Overall height with extended mast | in | mm | 236.6 | 6,009 | 236.6 | 6,009 | 236.6 | 6,009 | |
| 19 | Step height | in | mm | 9.4 | 240 | 9.4 | 240 | 9.4 | 240 | |
| 20 | Battery roller height | in | mm | 7.0 | 178 | 7.0 | 178 | 7.0 | 178 | |
| 21 | Load moment constant ^[2] | in | mm | 12.2 | 310 | 12.2 | 310 | 12.2 | 315 | |
| 22 | Minimum outside turning radius ^[3] | in | mm | 50.8 | 1,291 | 52.8 | 1,342 | 57.8 | 1,469 | |
| 23 | Minimum aisle – 90° stack – zero clearance ^[1] | in | mm | turning radius + load moment constant + load length + aisle clearance | | | | | | |
| Performance | | | | ECS14N | | ECS16N | | ECS18N | | |
| 24 | Travel speed, loaded / empty | mph | km/h | 8 / 8 | 12.9 / 12.9 | 8 / 8 | 12.9 / 12.9 | 8 / 8 | 12.9 / 12.9 | |
| 25 | Lift speed, loaded (triplex) | mph | km/h | 83 | 0.42 | 83 | 0.42 | 83 | 0.42 | |
| 26 | Lift speed, empty (triplex) | fpm | m/s | 118 | 0.60 | 118 | 0.60 | 118 | 0.60 | |
| 27 | Lower speed, loaded (triplex) | fpm | m/s | 102 | 0.52 | 102 | 0.52 | 102 | 0.52 | |
| 28 | Lower speed, empty (triplex) | fpm | m/s | 98 | 0.50 | 98 | 0.50 | 98 | 0.50 | |
| 29 | Gradeability, loaded (maximum) at 1 mph / 1.6 km/h | % | | 15 | | 15 | | 15 | | |
| 30 | Gradeability, empty (maximum) at 1 mph / 1.6 km/h | % | | 15 | | 15 | | 15 | | |
| Weight | | | | ECS14N | | ECS16N | | ECS18N | | |
| 31 | Truck weight – empty with minimum weight battery | lb | kg | 8,424 | 3,829 | 8,424 | 3,829 | 9,244 | 4,202 | |
| 32 | Battery weight (minimum) | lb | kg | 1,700 | 773 | 2,000 | 909 | 2,600 | 1,182 | |
| 33 | Battery weight (maximum) | lb | kg | 2,000 | 909 | 2,300 | 1,045 | 2,900 | 1,318 | |
| Chassis | | | | ECS14N | | ECS16N | | ECS18N | | |
| 34 | Chassis type, stand / sit | | | | stand | | stand | | stand | |
| 35 | Wheelbase ^[4] | in | mm | 41.7 | 1,059 | 43.7 | 1,110 | 48.7 | 1,237 | |
| 36 | Ground clearance – center of wheelbase | in | mm | 4.0 | 102 | 4.0 | 102 | 4.0 | 102 | |
| 37 | Ground clearance – lowest point at mast | in | mm | 3.0 | 76 | 3.0 | 76 | 3.0 | 76 | |
| 38 | Tire size, drive | in | | 16 x 7 x 10.5 | | 16 x 7 x 10.5 | | 16 x 7 x 10.5 | | |
| 39 | Tire size, steer | in | | 10 x 5 x 6.5 | | 10 x 5 x 6.5 | | 10 x 5 x 6.5 | | |
| 40 | Brake type | | | | electromagnetic disc | | electromagnetic disc | | electromagnetic disc | |
| Electrical | | | | ECS14N | | ECS16N | | ECS18N | | |
| 41 | Traction motor type | | | | AC induction | | AC induction | | AC induction | |
| 42 | Traction motor output kW (60 minute rating) | HP | kW | 5.4 (x2) | 4.0 (x2) | 5.4 (x2) | 4.0 (x2) | 5.4 (x2) | 4.0 (x2) | |
| 43 | Pump motor type | | | | AC induction | | AC induction | | AC induction | |
| 44 | Pump motor output kW (15% rating) | HP | kW | 17.4 | 13.0 | 17.4 | 13.0 | 17.4 | 13.0 | |
| 45 | Steer motor type | | | | AC induction | | AC induction | | AC induction | |
| 46 | Steer motor output kW (60 minute rating) | HP | kW | 0.9 | 0.7 | 0.9 | 0.7 | 0.9 | 0.7 | |
| 47 | Battery maximum capacity – A/H (6 hour rating) | AH | | | 1,240 | | 1,240 | | 1,240 | |
| 48 | Battery compartment length (front - back) | in | mm | 14.25 | 362 | 16.25 | 413 | 21.25 | 540 | |
| 49 | Battery compartment width (side - side) | in | mm | 38.50 | 978 | 38.50 | 978 | 38.50 | 978 | |
| 50 | Battery compartment height | in | mm | 32.00 | 813 | 32.00 | 813 | 32.00 | 813 | |

[1] Add load length and operator clearance.

[2] Add 2.25" (57.0 mm) for quad masts; add 2.50" (63.5 mm) for hang-on side shift / hang-on shift fork positioner options; Add 1.00" (25.4 mm) for integrated side shift

[3] Turning Radius: battery compartment 14.25" = 50.8" (1291mm); battery compartment 16.25" = 52.8" (1342mm); battery compartment 18.25" = 54.8" (1393mm); battery compartment 21.25" = 57.8" (1469mm);

[4] Wheelbase: battery compartment 14.25" = 41.7" (1059 mm); battery compartment 16.25" = 43.7" (1110 mm); battery compartment 18.25" = 45.7" (1161 mm); battery compartment 21.25" = 48.7" (1237 mm);

* Maximum converted value to gradeability at maximum torque of the traction motor.

NOTE: These specifications assume the use of drive axles, tires and tilt angles specified. Any modification to specifications, or any other combination of specifications made after the shipment of the truck, requires prior written approval from Logisnext Americas Inc. (See ANSI/ITSDF B56.1.) Also be advised that overall operating visibility may be affected by the mast configuration and mast options of your truck. Therefore, you may need to add ancillary (auxiliary) devices or modify your operating practices. Consult your dealer for further information.

Call-out numbers shown in the diagram correspond to the first column of the specifications chart.

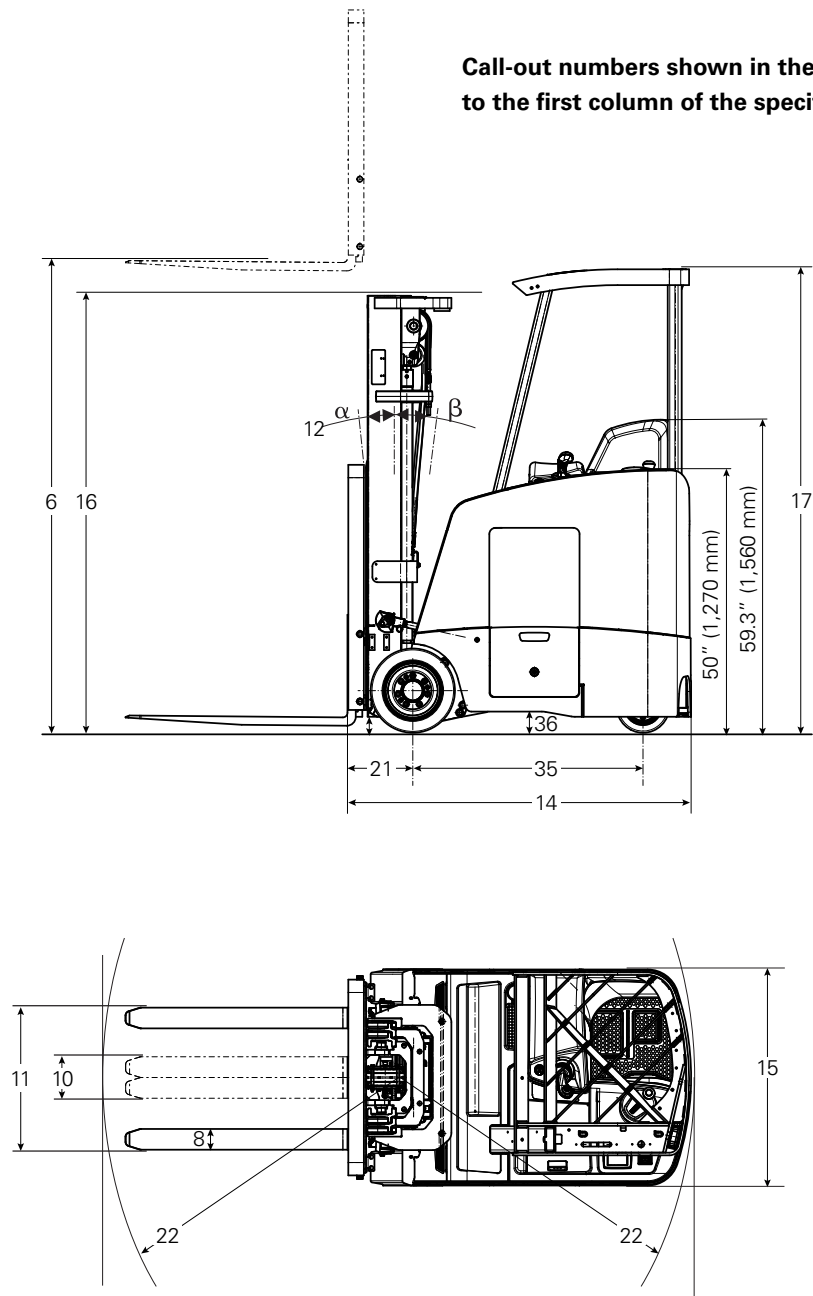

Note: Equipping this model (these models) with a power source (e.g. Lithium-ion, Hydrogen Fuel cell, etc.) that has not been previously approved by the factory is considered a modification. Per OSHA 1910.178 and ANSI/ITSDF B56.1, please consult with your factory representative prior to installing any non-OEM power source that has not been previously approved.

Safety Standards

These trucks meet American National Standards Institute/Industrial Truck Standards Development Foundation, ANSI/ITSDF B56.1.

UL-Classified by Underwriters Laboratories, Inc., as to fire and electric shock hazard only. Availability: Type E standard. Types ES and EE optional. Users should be aware of, and adhere to, applicable codes and regulations regarding operator training, use, operation and maintenance of powered industrial trucks, including:

- ANSI/ITSDF B56.1.
- NFPA 505, fire safety standard for powered industrial trucks - type designations, areas of use, maintenance and operation.
- Occupational Safety and Health Administration (OSHA) regulations that may apply.

Contact your Cat lift truck dealer for further information including operator training programs and auxiliary visual and audible warning systems, fire extinguishers, etc., as available for specific user applications and requirements. Specifications, equipment, technical data, photos and illustrations based on information at time of printing and subject to change without notice. Some products may be shown with optional equipment.



Your Cat lift truck dealer can provide additional options and features to specialize your lift truck for your unique application. Operator training and custom financing programs are also available to help find the right fit for your business.

Helping move businesses forward – that’s how we’re built.

1-800-CAT-LIFT | www.logisnextamericas.com/cat

© 2026 Logisnext Americas Inc. All Rights Reserved. CAT, CATERPILLAR, LET'S DO THE WORK, and their respective logos "Caterpillar CorporateYellow", the "Power Edge" and Cat "Modern Hex" trade dress as well as corporate and product identity used herein are trademarks of Caterpillar used under license and may not be used without permission from Caterpillar. All registered trademarks are the property of their respective owners.

Some products may be shown with optional equipment.

CECM0408

03/26

