



DESIGNED FOR EFFICIENCY

**1,500 – 3,500 KG. CAPACITY
ELECTRIC PNEUMATIC TIRE LIFT TRUCKS**





Made For Your Business

This series of electric lift trucks delivers all the enhancements you need to vastly increase warehouse productivity levels, while simultaneously improving safety standards. Engineered with your warehousing operations in mind, we have fitted our latest forklifts with all the features operators have demanded for - and advancements they didn't know they needed, until now. Simply put, these machines are smarter, faster, more comfortable to use and have more stamina than their counterparts.



E LONG HAUL

KEY ADVANTAGES:

In your line of work, efficiency and safety are essential. This series of lift trucks are designed to be your partner in productivity, and come with smart features that make these machines a breeze to work with.

- **Better Workflows** – Improve operator awareness in the warehouse with a load indicator, travel hydraulic interlocking system, overweight warnings and optional LED/spot lights.
- **Smooth, Stable Rides** – Stay in control with pitching reduction control, travel speed limiters and more.
- **Rugged Reliability** – Powered by an AC motor and protected with IPX4 waterproofing, this forklift is your reliable workhorse - in a dry warehouse, cold store or rainy outdoors.
- **Built For Productivity** – Boost your operators' productivity levels with intuitive fingertip controls personalized operation modes, an interactive display and other features.

THE ELECTRIC BENEFIT

See how an electric lift truck can save you more over the long run:

www.cat-lift.com

PRODUCTIVITY, FROM THE FIRST HOUR TO THE LAST

This series is designed with your productivity in mind. They are built with all the newest features you expect to see in modern lift trucks, and included brand-new, productivity-boosting innovations that can speed up your workflow.

TOTAL CONTROL

- **Auto Torque Up** – Climb slopes and carry heavy loads with ease. The EP-CB's built-in intelligence detects when additional power is needed and automatically increases torque to help ensure smooth, stress-free driving at all times.
- **Interactive Display** – The trucks use a single display to take over the role of multiple displays. Now, everything your operators need to view is shown in a high quality, easy-to-read display that's also interactive. This allows operators to not only see more, but also do more - such as adjust control function settings on-the-fly.
- **Fingertip Control (optional)** – Enable operators to take precise, efficient control of their lift trucks. Fingertip control allows operators to control hydraulics with a never-seen-before level of precision that levers simply cannot match enabling them to work faster, more accurately and more safely.
- **Intelligent Load Indicators and Limits (Option)** – A load indicator* gives operators a general idea of the loads they're carrying. The truck also intelligently reduces its travel speed according to its current load weight and lift weight. If it's carrying too much, an overweight warning is set off.





EXCEPTIONAL EFFICIENCY



To Get The Job Done

This series of lift trucks has been built with both operator awareness and efficiency in mind. Some of these innovations include:

A SMOOTH, STABLE RIDE

Enjoy a stable ride, all day long. These truck's low center of gravity and electronic pitching control deliver a ride so stable and comfortable, it's almost like driving a car. Even on bumpy roads, pitching control reduces mast shaking and overall wobbles. A wide field of view helps to ensure operators retain awareness of their surroundings at all times.

REDUCING COMPLACENCY

Human error is reduced too, as the truck's smart travel hydraulic interlock prevents operators from activating the mast or moving until they're properly seated. Once operators are done with their shift and ready to get off, an intuitive parking brake warning goes off if the parking brakes are not engaged.

INCREASED OPERATOR AWARENESS

Other awareness features that operators will appreciate include an easily accessible and unobstructed emergency stop button, a highly visible orange seatbelt (optional), and optional password system that restricts the access and operation of the truck to authorized personnel.



A RUGGED, RELIABLE PERFORMER



Dependability You Can Count On

Warehouse work can be tough, and you need a machine you can rely on, through good times and bad. These trucks are designed to be rugged, reliable performers that give operators more performance - with less hassle and maintenance.

Better Efficiency with an AC Motor

High-quality AC motor drives these trucks, delivering smooth rides, faster acceleration and greater responsiveness - while optimizing the lifespan of your lift trucks battery and keeping maintenance requirements low.

IPX4 Waterproofing

Whether in a warehouse or in the rain, you can count on these trucks to keep running reliably, thanks to IPX4 waterproofing.

Efficiency You Can Bank On

Experience the joy of operating one of the most energy-efficient lift trucks available. The EP-CB's low energy usage translates into lower operating costs, longer battery life, more operating hours and less downtime. You have a warehouse to run, and your lift trucks will support you all the way.

ECOMode

Extend the operating hours of your lift trucks with a simple press of the ECO mode button, which switches the truck into energy-saving mode.

Auto Power Off

This truck automatically shuts off after 15 minutes of inactivity - conserving battery life for actual warehouse operations, and not while it's on standby.

Go Longer with Regeneration

Innovative technology in the truck translates movements such as coasting, plugging, downhill travel, braking, speed suppression and controlled rollbacks into kinetic energy that charges the truck's battery as it's being used - extending operating time.



Local service and support



Genuine OEM parts



Custom financing packages

MORE CONFIDENCE





Factory warranty for added protection



Local Support You Can Count On

A Cat lift truck purchase connects you to a variety of material handling solutions, including world-class service and support from your local, trusted dealer. With factory-trained service technicians, a diverse parts inventory and a broad selection of service options, your local dealer can help you lower costs, enhance productivity and more efficiently manage your business.

FINANCING MADE SIMPLE

Financing your next Cat lift truck is easy with our wide range of flexible leasing and purchasing options. Whether you want to finance or lease, your local Cat lift truck dealer can help customize a package for your business.

WHEN EVERY PART COUNTS

When buying from your local Cat lift truck dealer, you can rest assured that your genuine OEM parts are manufactured to meet original equipment criteria. Additionally, all Cat lift truck OEM parts come with a six-month, unlimited-hours warranty.

When speed is critical, our Parts Fast Or Parts Free Guarantee* ensures next-business-day delivery of all Cat lift trucks parts, or they're free, including freight. If your part doesn't come in by the next business day, we pay for it.

STANDING BEHIND OUR PRODUCTS

We deliver peace of mind by helping your lift trucks stay on the job. Every new Cat lift truck is covered by a 1-year / 2,000-hours warranty that includes parts and labor, as well as components and systems. With our standard 2-year / 4,000-hours extended powertrain warranty, you'll have the confidence that only comes from owning a Cat lift truck.

* At dealer's location.

† Programs may be subject to change without notice and may vary by region. Please ask your local Cat lift truck dealer for complete terms and conditions.

Specifications

Characteristics			EP15CB	EP18CB	EP20CB
1	Rated Capacity	kg	1,500	1,750	2,000
2	Load Center	mm	500	500	500
3	Motor Type		AC	AC	AC
4	Operator Type		Seated	Seated	Seated
Dimensions			EP15CB	EP18CB	EP20CB
5	Lift Height	mm	3,000	3,000	3,000
6	Free Lift	mm	115	115	145
7	Tilt Angle	deg	7 / 11	7 / 11	7 / 11
8	Carriage – Class II, III	mm	Class II	Class II	Class II
9	Fork Dimensions – T / W / L	mm	35 x 100 x 1,070	35 x 100 x 1,070	45 x 100 x 1,070
10	Fork Spread (max. / min.)	mm	920 / 240	920 / 240	975 / 240
11	Overall Length	mm	3,150	3,190	3,375
12	Length To Fork Face	mm	2,080	2,120	2,305
13	Overall Width	mm	1,100	1,115	1,155
14	Height - Mast Lowered	mm	1,990	1,990	1,995
15	Height – Mast Extended	mm	4,055	4,055	4,055
16	Height of Overhead Guard	mm	2,110	2,110	2,110
17	Front Overhang	mm	395	395	445
18	Minimum Turning Radius	mm	1,850	1,880	2,030
Performance			EP15CB	EP18CB	EP20CB
19	Travel Speed - loaded / unloaded (pneumatic tire)	km/h	14.0 / 16.0	13.5 / 15.5	14.0 / 16.0
20	Travel Speed - loaded / unloaded (no-puncture tire)	km/h	13.0 / 15.0	12.5 / 14.5	13.0 / 15.0
21	Lifting Speed - loaded / unloaded	mm/s	350 / 540	350 / 540	290 / 470
22	Lowering Speed - loaded / unloaded	mm/s	500 / 470	500 / 470	480 / 440
23	Maximum Gradeability - 3 min. rating, 1.5km/h +	%	19	17	19
Weights			EP15CB	EP18CB	EP20CB
24	Service Weight without battery	kg	2,250	2,495	2,960
25	Service Weight with battery	kg	2,920	3,165	3,780
26	Axle Loading - loaded (front / rear)	kg	3,920 / 500	4,320 / 595	5,090 / 690
27	Axle Loading - unloaded (front / rear)	kg	1,465 / 1,455	1,450 / 1,715	1,850 / 1,930
Wheels / Chassis			EP15CB	EP18CB	EP20CB
28	Tires - number front / rear		2 / 2	2 / 2	2 / 2
29	Tire Size - front	mm	6.00-9 Solid	21x8-9 Solid	21x8-9 Solid
30	Tire size - rear	mm	5.00-8 Solid	5.00-8 Solid	18x7-8 Solid
31	Wheelbase	mm	1,410	1,410	1,520
32	Tread - front	mm	930	925	955
33	Tread - rear	mm	900	900	965
34	Ground Clearance - at mast	mm	110	110	115
35	Ground Clearance - at middle of wheelbase	mm	110	110	110
36	Service Brake		2xDrum	2xDrum	2xDrum
37	Parking Brake		Mechanical	Mechanical	Mechanical
38	Power Steering type		Electro-hydraulic Power Steering	Electro-hydraulic Power Steering	Electro-hydraulic Power Steering
Engine / Transmission			EP15CB	EP18CB	EP20CB
39	Battery type		JIS	JIS	JIS
40	Battery Voltage	V/Ah	48 / 415	48 / 415	48 / 510
41	Drive Motor - 60 min. rating	kW	7.0	7.0	8.5
42	Hydraulic Motor 5 min. rating	kW	9.5	9.5	11.5
43	Power Steering Motor - 60 min. rating	kW	1.5	1.5	1.5
44	Motor Control		AC Inverter	AC Inverter	AC Inverter

NOTE: Dimensions represent maximum battery size, not compartment size. These specifications assume the use of drive axles, tires and tilt angles specified. Any modification to specifications, or any other combination of specifications made after the shipment of the truck, requires prior written approval from Logisnext Americas Inc.(ISO 3691-1) Also be advised that overall operating visibility may be affected by the mast configuration and mast options of your forklift truck. Therefore, you may need to add ancillary [auxiliary] devices or modify your operating practices. Consult your dealer for further information.

	EP25CB	EP30CB	EP35CB
1	2,500	3,000	3,500
2	500	500	500
3	AC	AC	AC
4	Seated	Seated	Seated
EP25CB	EP30CB	EP35CB	
5	3,000	3,000	3,000
6	145	140	140
7	7 / 11	7 / 11	7 / 11
8	Class II	Class III	Class III
9	45 x 100 x 1,070	45 x 122 x 1,070	45 x 122 x 1,070
10	975 / 240	995 / 280	995 / 280
11	3,415	3,575	3,670
12	2,345	2,505	2,590
13	1,155	1,255	1,255
14	1,995	2,015	2,115
15	4,055	4,055	4,055
16	2,110	2,260	2,330
17	445	485	490
18	2,215	2,260	2,285
EP25CB	EP30CB	EP35CB	
19	14.0 / 16.0	13.5 / 15.5	13.5 / 15.5
20	13.0 / 15.0	12.5 / 14.5	12.5 / 14.5
21	260 / 470	320 / 550	270 / 460
22	480 / 440	450 / 450	450 / 450
23	16	16	13
EP25CB	EP30CB	EP35CB	
24	3,335	3,915	4,445
25	4,190	5,070	5,600
26	5,610 / 1,080	7,155 / 915	7,955 / 1,145
27	2,030 / 2,160	2,390 / 2,680	2,380 / 3,220
EP25CB	EP30CB	EP35CB	
28	2 / 2	2 / 2	2 / 2
29	21x8-9 Solid	28x9-15 Solid	28x9-15 Solid
30	18x7-8 Solid	6.50-10 Solid	6.50-10 Solid
31	1,520	1,680	1,680
32	955	1,030	1,030
33	965	980	980
34	115	130	130
35	110	120	120
36	2xDrum	2xDrum	2xDrum
37	Mechanical	Mechanical	Mechanical
38	Electro-hydraulic Power Steering	Electro-hydraulic Power Steering	Electro-hydraulic Power Steering
EP25CB	EP30CB	EP35CB	
39	JIS	JIS	JIS
40	48 / 565	72 / 470	72 / 470
41	8.5	11.0	11.0
42	11.5	15.0	15.0
43	1.5	1.7	1.7
44	AC Inverter	AC Inverter	AC Inverter

Call-out numbers shown in diagram correspond to the first column of the specifications chart.

EP15CB-EP35CB

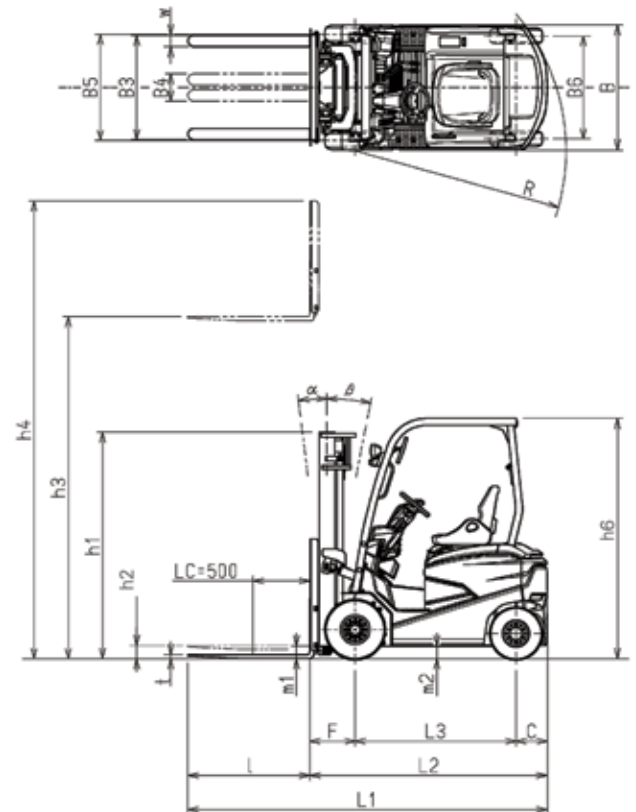

Safety Standards

Users should be aware of, and adhere to, applicable codes and regulations regarding operator training, use, operation and maintenance of powered industrial trucks, including:

- ISO 3691-1

Specifications, equipment, technical data, photos and illustrations based on information at time of printing and subject to change without notice. Some products may be shown with optional equipment.

Note: Equipping this model (these models) with a power source (e.g. Lithium-ion, Hydrogen Fuel cell, etc.) that has not been previously approved by the factory is considered a modification.



Your Cat lift truck dealer can provide additional options and features to specialize your lift truck for your unique application. Operator training and custom financing programs are also available to help find the right fit for your business.

Helping move businesses forward – that's how we're built.

1-800-CAT-LIFT | www.logisnextamericas.com/cat

© 2026 Logisnext Americas Inc. All Rights Reserved. CAT, CATERPILLAR, LET'S DO THE WORK, and their respective logos "Caterpillar Corporate Yellow," the "Power Edge" and Cat "Modern Hex" trade dress as well as corporate and product identity used herein are trademarks of Caterpillar used under license and may not be used without permission from Caterpillar. All registered trademarks are the property of their respective owners.

Some products may be shown with optional equipment.

CECM0406

03/26

